

OPERATION MANUAL
FOR DISPLAYS OF
SERIE DT-203NW, DT-105NW, DT-106NW,
DT-110NW AND DT-111NW

Index

<u>1.-INTRODUCTION</u>	1-1
<u>2.-GENERAL CHARACTERISTICS</u>	2-1
2.1 Electrical characteristics of DT-203NW displays	2-1
2.2 Electrical characteristics of DT-105NW displays	2-2
2.3 Electrical characteristics of DT-106NW displays	2-2
2.4 Electrical characteristics of DT-110NW displays	2-3
2.5 Electrical characteristics of DT-111NW displays	2-3
2.6 Displays weight	2-2
2.7 Characteristics of temperature & humidity probe (Option)	2-3
2.8 Wiring of temperature & humidity probe (Option)	2-3
2.9 Dimensions	2-4
<u>3.-INSTALLATION</u>	3-1
3.1 Power Supply	3-1
3.2 Connecting the antenna.....	3-2
<u>4.-OPERATION</u>	4-1
4.1 Initial Start Up.....	4-1
4.2 Programming the Parameters.....	4-1
4.2.1 Enter to modify parameters.....	4-2
4.2.2 Exit modify parameters	4-2
4.2.3 Function of each parameter	4-2
4.3 Protocols	4-5
4.4 IP Address.....	4-6
4.5 IP Address set up with DeviceInstaller	4-10
4.6 Modifying the port settings.....	4-11

CE STATEMENT OF CONFORMITY

1. Introduction.

The alphanumeric displays for series **DT-203NW**, **DT-105NW**, **DT-106NW**, **DT-110NW** and **DT-111NW**, are industrial displays for control by Ethernet network and can be configured for use with TDL, TCP/IP and Modbus/TCP protocols.

The selection of the parameters and the communication protocol is done using two buttons with a system of easily programmable menu.

One of its main characteristics is the large size of the characters,

DT-203NW of **30mm** legible at 15m.

DT-105NW of **50 mm** legible at 25m. Protection IP41.

DT-106NW of **50 mm** legible at 25m. Protection IP54.

DT-110NW of **100 mm** legible at 50m. Protection IP41.

DT-111NW of **100 mm** legible at 50m. Protection IP54.

As with other display series, the **DT-203NW**, **DT-105NW**, **DT-106NW**, **DT-110NW** and **DT-111NW** series is also available in **one or two-sided** versions, which provides multiple solutions and installation possibilities.

It is surface mounted, with fixtures to a wall or partition wall, or suspended by the side anchoring.

The application field of these displays is very wide in all types of industrial applications utilising the advantages of the Ethernet network. They can be used to display Scada program values, counter values from a PLC, warning messages, advertisements.

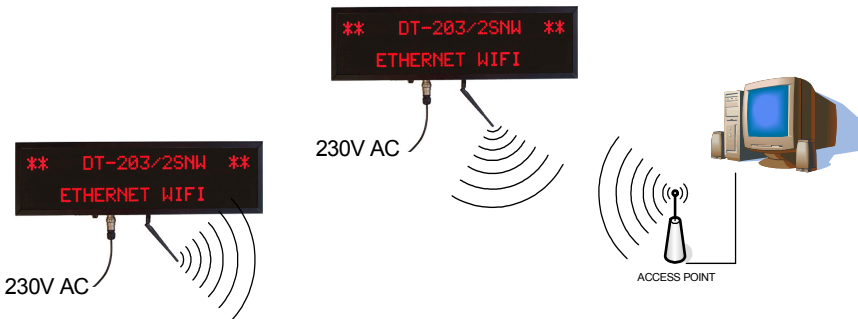

2. General characteristics.

2.1 Electrical characteristics of the DT-203NW displays.

Supply Voltage	100 VAC to 240 VAC 50/60Hz
Consumption	1 Side = (5 + (10 x lines)) VA.
.....	2 Sides = (5 + (20 x lines)) VA
Display	7x5 Dot matrix of 30mm in height
.....	Red Led colour. Visibility 15 meters.
Parameter memory	Eeprom.
Watch calendar	Second / Minute / Hour / Day / Month / Year
Communication	IEEE 802.11b and IEEE 802.11g
Communication Protocols	TDL, TCP/IP and Modbus/TCP.
Environmental Conditions	Operation Temperature: 0 to 50°C.
.....	Storage temperature-10°C to 60°C
.....	Humidity 5-95% without condensation
.....	Maximum environmental illumination: 1000 lux.
.....	Protection IP41.

2.2 Electrical characteristics of the DT-105NW displays.

Supply Voltage	100 VAC to 240 VAC 50/60Hz
Consumption	1 Side = (5 + (20 x lines)) VA.
.....	2 Sides = (5 + (40 x lines)) VA
Display	7x5 Dot matrix of 50mm in height
.....	Red Led colour. Visibility 25 meters.
Parameter memory	Eeprom.
Watch calendar	Second / Minute / Hour / Day / Month / Year
Communication	IEEE 802.11b and IEEE 802.11g
Communication Protocols	TDL, TCP/IP and Modbus/TCP.
Environmental Conditions	Operation Temperature: 0 to 50°C.
.....	Storage temperature-10°C to 60°C
.....	Humidity 5-95% without condensation
.....	Maximum environmental illumination: 1000 lux.
.....	Protection IP41.

2.3 Electrical characteristics of the DT-106NW displays.

Same characteristics than **DT-105NW** but the level protection is IP54.

2.4 Electrical characteristics of the DT-110NW displays.

Supply Voltage	100 VAC to 240 VAC 50/60Hz
Consumption	1 Side = (5 + (90 x lines)) VA.
.....	2 Sides = (5 + (180 x lines)) VA
Display	7x5 Dot matrix of 100mm in height
.....	Red Led colour. Visibility 50 meters.
Parameter memory	Eeprom.
Watch calendar	Second / Minute / Hour / Day / Month / Year
Communication	IEEE 802.11b and IEEE 802.11g
Communication Protocols	TDL, TCP/IP and Modbus/TCP.
Environmental Conditions	Operation Temperature: 0 to 50°C.
.....	Storage temperature-10°C to 60°C
.....	Humidity 5-95% without condensation
.....	Maximum environmental illumination: 1000 lux.
.....	Protection IP41.

2.5 Electrical characteristics of the DT-111NW displays.

Same characteristics than **DT-110NW** but the level protection is IP54.

2.6 Displays weight

DT-105(106) = Model DT-105 and DT-106

DT-110(111) = Model DT-110 and DT-111

Model	Weight	Model	Weight	Model	Weight
		DT-105(106)/1SNW	6 kg	DT-110(111)/1SNW	14 kg
		DT-105(106)/1DNW	7 kg	DT-110(111)/1DNW	19 kg
DT-203/2SNW	5 kg	DT-105(106)/2SNW	9 kg	DT-110(111)/2SNW	20 kg
DT-203/2DNW	6 kg	DT-105(106)/2DNW	12 kg	DT-110(111)/2DNW	32 kg
		DT-105(106)/3SNW	12 kg	DT-110(111)/3SNW	26 kg
		DT-105(106)/3DNW	17 kg	DT-110(111)/3DNW	44 kg
DT-203/4SNW	7 kg	DT-105(106)/4SNW	16 kg	DT-110(111)/4SNW	32 kg
DT-203/4DNW	9 kg	DT-105(106)/4DNW	22 kg	DT-110(111)/4DNW	56 kg
		DT-105(106)/5SNW	19 kg	DT-110(111)/5SNW	38 kg
		DT-105(106)/5DNW	27 kg	DT-110(111)/5DNW	68 kg
DT-203/6SNW	10 kg	DT-105(106)/6SNW	22 kg	DT-110(111)/6SNW	44 kg
DT-203/6DNW	15 kg	DT-105(106)/6DNW	32 kg	DT-110(111)/6DNW	86 kg
		DT-105(106)/7SNW	26 kg	DT-110(111)/7SNW	50 kg
		DT-105(106)/7DNW	37 kg	DT-110(111)/7DNW	92 kg
DT-203/8SNW	12 kg	DT-105(106)/8SNW	29 kg	DT-110(111)/8SNW	56 kg
DT-203/8DNW	18 kg	DT-105(106)/8DNW	42 kg	DT-110(111)/8DNW	104 kg

2.7 Characteristics of temperature & humidity probe. (Option)

Relative humidity

Resolution.....Typical 1%

Accuracy..... $\pm 3,5\%$ between 30% y 70%

Delay time 4s.

Temperature

Resolution.....Typical 0,1°C

Accuracy $\pm 0,5^\circ\text{C}$ at 25°C

Delay time20s.

Range.....From -20°C to $+80^\circ\text{C}$.

2.8 Wiring of temperature & humidity probe (Option)

The temperature & humidity probe is delivered with 5m cable and a Sub-D9 connector ready to use.

The wiring of connector probe is shown in the diagram.

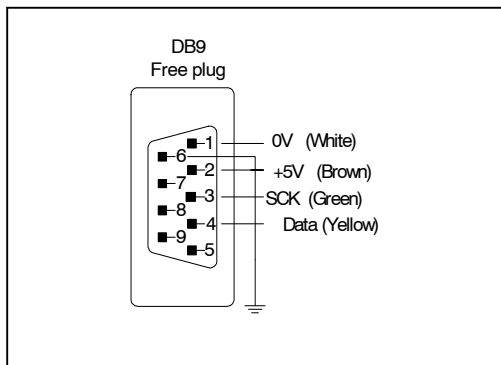

Temperature & humidity probe connector

The connector refers to the type of cable connector

2.9 Dimensions of DT-203NW, DT-105NW, DT-106NW, DT-110NW and DT-111NW displays.

DT-105(106) = Model DT-105 and DT-106

DT-110(111) = Model DT-110 and DT-111

	A	B	C	D	E	F	G	P1	P2	P3
DT-203/2S(D)NW	615	170	85	X	X	X	156	O	X	X
DT-203/4S(D)NW	615	317	X	72	173	X	303	X	O	O
DT-203/6S(D)NW	615	464	X	91	282	X	450	X	O	O
DT-203/8S(D)NW	615	611	X	112	387	X	597	X	O	O
DT-105(106)/1S(D)NW	985	118	109	X	X	X	104	O	X	X
DT-105(106)/2S(D)NW	985	224	112	X	X	X	210	O	X	X
DT-105(106)/3S(D)NW	985	330	X	72	186	X	316	X	O	O
DT-105(106)/4S(D)NW	985	436	X	72	292	X	422	X	O	O
DT-105(106)/5S(D)NW	985	542	X	92	358	X	528	X	O	O
DT-105(106)/6S(D)NW	985	648	X	112	424	X	634	X	O	O
DT-105(106)/7S(D)NW	985	754	377	72	610	305	740	O	O	O
DT-105(106)/8S(D)NW	985	860	430	72	716	358	846	O	O	O
DT-110(111)/1S(D)NW	1886	165	82,5	X	X	X	151	O	X	X
DT-110(111)/2S(D)NW	1886	378	X	80	218	X	364	X	O	O
DT-110(111)/3S(D)NW	1886	590	X	80	430	X	577	X	O	O
DT-110(111)/4S(D)NW	1886	806	403	80	646	323	791	O	O	O
DT-110(111)/5S(D)NW	1886	1018	509	80	858	429	1004	O	O	O
DT-110(111)/6S(D)NW	1886	1232	616	80	1072	536	1218	O	O	O
DT-110(111)/7S(D)NW	1886	1446	723	80	1286	643	1431	O	O	O
DT-110(111)/8S(D)NW	1886	1660	830	80	1500	750	1645	O	O	O

See the draw on the next page

Measures in millimetres. X = Not valid for these model.

P1, P2 and P3: Anchorage point. Used = O. Not used = X.

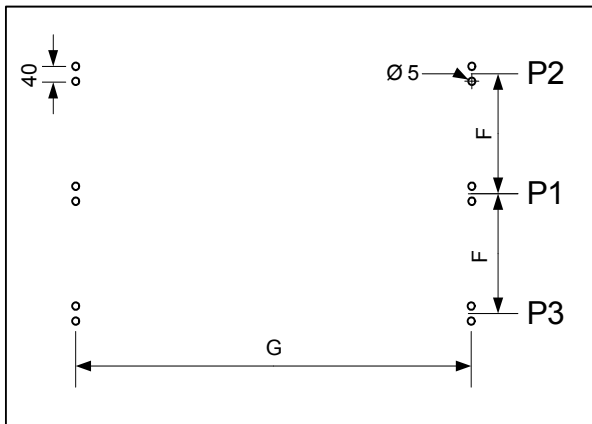
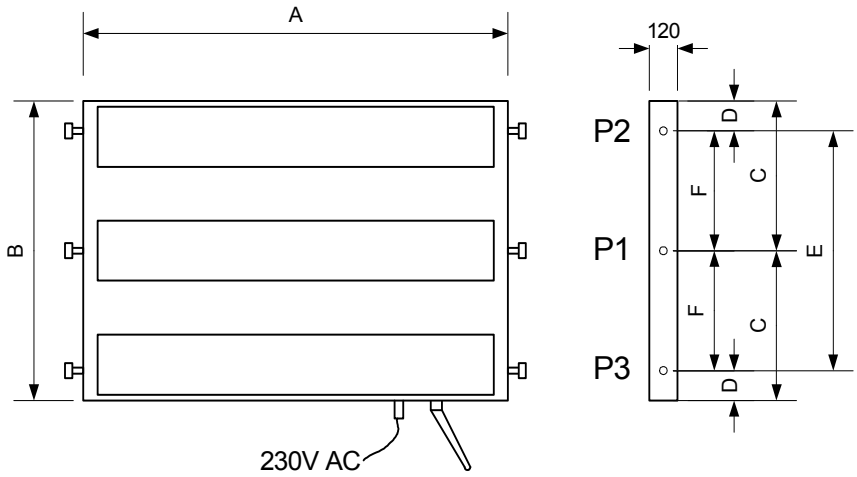

Anchorage holes position on the wall. See valid point (P1, P2 o P3) on the table in the previous page.

3. Installation.

The installation of the **DT-203NW**, **DT-105NW**, **DT-106NW**, **DT-110NW** y **DT-111NW**, is not particularly delicate but some important considerations must be taken into account. It must not be anchored to places subject to vibrations, nor should it be installed in places which generally surpass the limits specified in the display characteristics, both in terms of temperature and humidity.

The protection rating of displays **DT-203NW**, **DT-105NW** and **DT-110NW** is IP41. The protection rating of displays **DT-106NW** and **DT-111NW** is IP54.

Displays **DT-203NW**, **DT-105NW**, **DT-106NW**, **DT-110NW** y **DT-111NW**, should not be installed in places with an illumination level in excess of 1000 lux. Neither should the display be placed in direct sunlight as visibility would be lost.

In the electrical installation, proximity to lines of high intensity circulation and high voltage lines must be avoided, as well as proximity to High Frequency generators and U/F converters for motors.

3.1 Power supply.

The power supply must be **100VAC to 240VAC, 50/60 Hz**.

The protection fuse built into the equipment is according power. If for any reason it is necessary to change the fuse, select the value in the table + 1A. **Minimum value 2A**.

Current consumption:

	DT-203/NW	DT-203/NW	DT-105/NW	DT-105/NW	DT-110/NW	DT-110/NW
	1 Side	2 Sides	DT-106/NW	DT-106/NW	DT-111/NW	DT-111/NW
1 Line	-----	-----	0,1A	0,2A	0,5A	0,9A
2 Lines	0,15A	0,25A	0,2A	0,4A	0,9A	1,7A
3 Lines	-----	-----	0,3A	0,6A	1,3A	2,5A
4 Lines	0,25A	0,45A	0,4A	0,8A	1,7A	3,3A
5 Lines	-----	-----	0,5A	1,0A	2,1A	4,1A
6 Lines	0,35A	0,65A	0,6A	1,2A	2,5A	4,9A
7 Lines	-----	-----	0,7A	1,4A	2,9A	5,7A
8 Lines	0,45A	0,85A	0,8A	1,6A	3,3A	6,5A

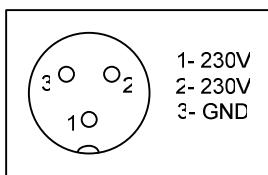

3.1 230 VAC Power Supply

The power supply conductor section will be in line with consumption and the earth conductor will be a minimum section of 1.5m².

Although the displays are specially prepared for environments with high levels of electrical noise, should you suspect that the power supply line is very noisy, we advise a separating transformer be connected between the supply line and the display and/ or an exterior network filter be connected

The power supply connector has 3 contacts and is situated in the lower part of the unit. The connection should be carried out following figure 3.1

3.2 Connecting the antenna

Wifi connection is carried out using an antenna located in the lower part of the unit.



4. Operation.

4.1 Initial Start Up.

Before connecting the display to the network, we must ensure that all of the connections have been carried out correctly and that the display is firmly in place.

Every time the display is connected to the power supply there is an initial reset, which check all points of the display. After the initial reset the version code is displayed.

Following the initial reset, the display reads the message memory and initialises the messages table. The word "INICI" is shown until the display is prepared to receive messages.

When the initialisation process is finished, the display is ready to receive data. While waiting for the first message the display shows a programmed message on the memory.

4.2 Programming the Parameters.

Before using the display you must set the parameters:

The parameters are:

- 1- LANGUAGE: Language of menu
- 2- PROTOCOL: Protocol selected
- 3- END BLOCK: End of bloc code.
- 4- REPLAY: Reply message.
- 5- MAC code.
- 6- RESET XPORT: Load the default configuration to the Wifi port.
- 7- CONFIG. WIFI: To set up the IP address using the serial port.
- 8- DATE: Modify the display's date.
- 9- TIME: Modify the display's time.
- 10- BRIGHTNESS: Adjust the level luminosity of leds.
- 11- END: Exit the menu.

To set the parameters, the display has a pair of pushbuttons located at the bottom of the case. The menu is in four languages.

4.2.1 Enter to modify parameters.

In order to enter the sequence to modify the parameters, the Advance key "7-> 5" must be pressed and held for three seconds. After this, the first parameters will be displayed, with the digit flashing.

There are then two options:

1- Modify the parameter value

By pressing the Advance key "7->5", entry is gained to modify the parameter value.

To go back to displaying the parameter number, press "7->5" again.

To increase the parameter value, press the "+" key. After parameter EXIT it returns to parameter LANGUAGE.

2- Select another parameter

In order to select another parameter, the parameter number must be made to flash using the "7->5" key and then the new parameter may be selected using the "+" key.

4.2.2 Exit modify parameters.

In order to exit the sequence for modifying parameters, parameter EXIT must be selected then press "7->5".

4.2.3 Function of each parameter.

4.2.3.1 Parameter 1: LANGUAGE.

The language menu. There are four languages available: **Catalan, Spanish, French and English.**

4.2.3.2 Parameter 2: PROTOCOL.

The selected protocol. The protocols available are:

- **TDL** To program message with TDLWin. Port 10001.
- **TCP/UDP:** To be used with TCP/IP or UDP/IP. Port 10001.
- **Modbus/TCP:** To be used with Modbus/TCP protocol. Port 502.

Before using TCP/IP or UDP/IP protocol you must program the Ethernet port using the DeviceInstaller software (available from Lantronix web).

4.2.3.3 Parameter 3: END BLOCK.

Allows for code selection to indicate that the block has been completely sent.

End of block
0x0D
0x0A
0x0D 0x0A
0x0A 0x0D
0x03
0x02
0x2A 0x0D
0x04

4.2.3.4 Parameter 4: REPLAY

For configuring the display's reply message.

Value	Replay message
NO	Without replay
0x06 +	0x06 + End of block
ACK +	ACK + End of block
0x06 +	0x06
ACK +	ACK

End of block is the end of the block selected in parameter 2.

If value 1 has been selected, the hexadecimal code 06 is sent, followed by the block selected in parameter 2

If value 2 has been selected, the ACK characters are sent followed by the block selected in parameter 2

4.2.3.5 Parameter 5: MAC Code

The MAC code is a code which identifies each port which connects to an Ethernet network. It is unique to each unit and is needed to configure the port. The MAC code is formed by 6 bytes in a hexadecimal format.

Example: MA: 00-20-4A-8A-E5-6C

4.2.3.6 Parameter 6: RESET XPORT

If the configuration of the port has been modified and the factory parameters cannot be reset, this parameter can be used to load them.

To load the factory parameters, value 999 must be input and the advance key "7->5" pressed. During the parameter loading time, a waiting message is displayed. After resetting the port the blinking message RESET XPORT is displayed.

4.2.3.7 Parameter 7: CONFIG. WIFI

Set up the IP address using the serial port.

To set up the IP address you may use the serial line and a computer with the Hyperterminal. See 4.4.

4.2.3.8 Parameter 8: DATE

Allows you to modify the display date.

4.2.3.9 Parameter 9: TIME

Allows you to modify the display time.

4.2.3.10 Parameter 10: BRIGHTNESS.

Allows you to modify the display brightness. Level 1 is the minimum brightness while level 8 is the maximum brightness.

4.2.3.11 Parameter 11: EXIT.

To exit modify parameter menu, push advance key ("7->5").

4.3 Protocols.

Three protocols are available to communicate with the display: **TDL, TCP/IP and Modbus/TCP.**

TDL: Use TDL protocol to download messages into the displays memory with the TDLWin software. Port 10001 must be used.

TCP/IP: With this protocol is easy to communicate many other devices. The block structure is explained in paragraph 4.3.1. Port 10001 must be used.

Modbus/TCP: Use this protocol to communicate with Modbus protocol over TCP/IP. Port 502 must be used.

4.3.1 Block Structure. Protocol TCP/IP:

In order for the display to be able to accept a block, it must end with an end of block that is recognised by the display. The end of block coding which the display expects to receive can be found in section 4.2.3.2.

4.3.2 Valid characters. Protocols TCP/IP and Modbus/TCP:

Alphanumerical displays can display all the alphabet characters, numbers and some special characters. The special characters are show below.

↑↓→←▲▼! "#\$%&' () * + , - . / : ; < = > ? @ £ ¥ ° ≤ ≥ ± Ω α β « » ¡ €

4.3.3 Control characters. Protocols TCP/IP and Modbus/TCP:

Control characters are used in conjunction with valid characters to extend the edition capabilities. The extension includes display variables, blinking characters, set timer, modify brightness.

- 8 (08h) Beginning of blinking, in the following characters.
- 9 (09h) Ending of blinking.
- 10(0Ah) Line feed. The same as code 12(0Ch).
- 11(0Bh) + Line number. Jump to line number in ASCII.
- 12(0Ch) Line feed. The same as code 10(0Ah).
- 18(12h) + n. Brightness control. n in ASCII. n = 1 Minimum. n = 8 Maximum.
- 21(15h) Displaying the date. DD/MM/YY
- 22(16h) Displaying hour and minutes. HH:MM
- 23(17h) Displaying the date. DD/MM/YYYY
- 24(18h) Displaying hour, minutes and seconds. HH:MM:SS
- 25(19h) Setting time and date.
 - 25 DDMMYY HHMM Between year units and hour tens should be a blank space..

Only with humidity and temperature option present.

- 26(1Ah) Displaying temperature in Celsius. Format: ±CC.C°
- 27(1Bh) Displaying temperature in Fahrenheit. Format: ±FF.F°
- 28(1Ch) Displaying relative humidity. Format HH%

4.4 IP Address.

The easiest way to set up the IP address is by using the Hyperterminal program and the serial line of computer. The cable's wiring diagram is the classic crossover.

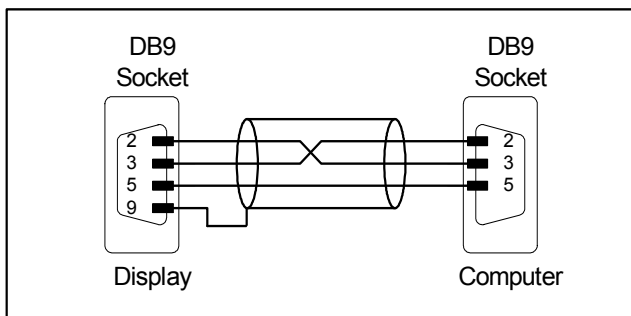

Cable's wiring diagram between display and a computer

The set up Hyperterminal is:

Baud rate: 9600 Bauds
Data Bits: 8
No parity
Stop Bits: 1
Hardware flow control: None.

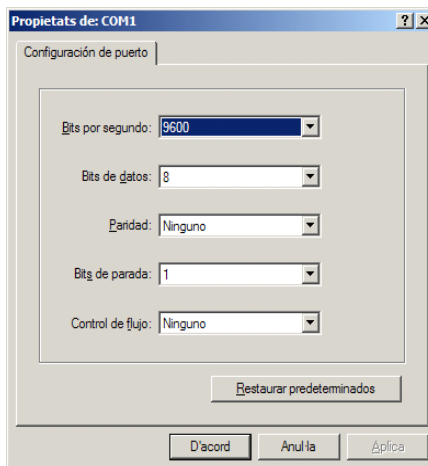

The attached Hyperterminal set up have been verified and work correctly, but any other set up may work also correctly.

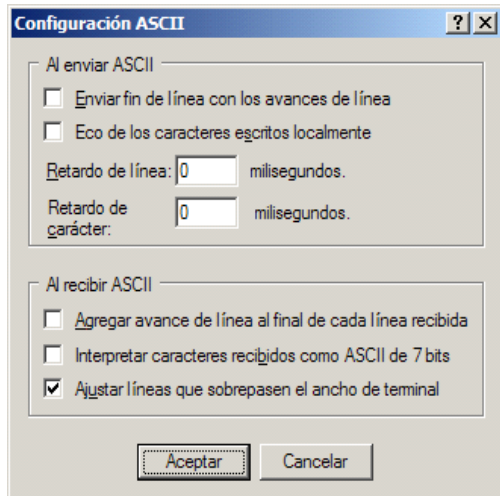
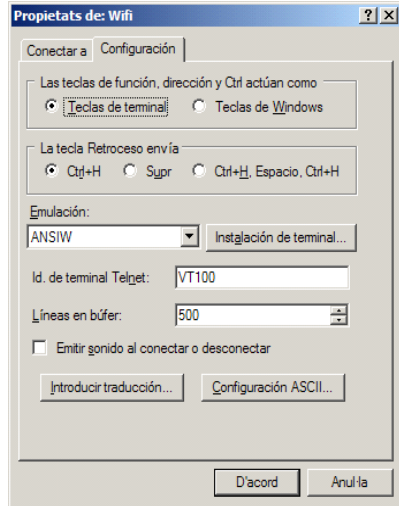

To set up the Wifi module using the Hyperterminal or any other program, you must follow a time sequence. A time error on steps 5 and 6 forces to return to step 3.

4.4.1 Access to Wifi module configuration.

In order to access to Wifi module configuration the next steps must be followed:

- 1– Connect the serial cable (see 4.4) between the computer and the display.
- 2– Open Hyperterminal.
- 3– Select the display's parameter 7. See 4.2.1.
- 4- Push the advance key. (Key 7->5)

5– Keep pushed the lower case letter **x** before the display counters equals 0. Remain pushing until the right screen is displayed.

The maximum delay since to push the advance key (step 4) until to push x key is 10 seconds.

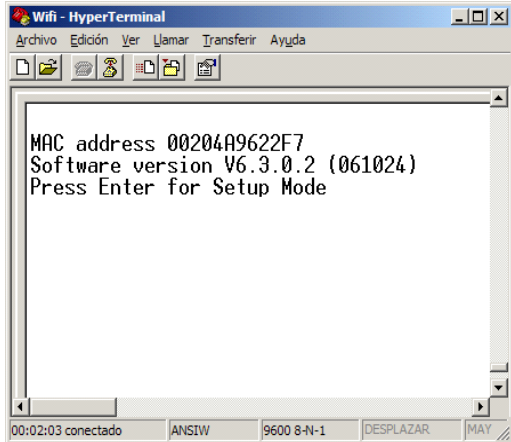

6– At this time you have **3 seconds** to push the Intro key on your keyboard .

7– The screen on the right is shown.

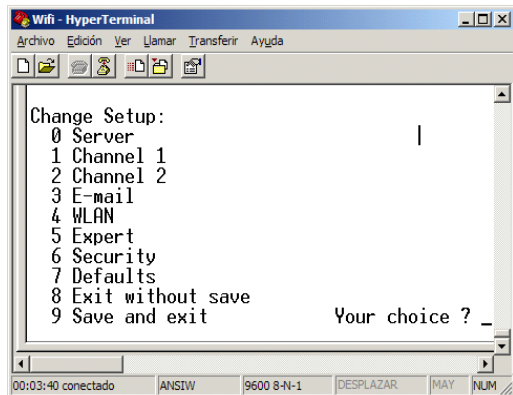

8– You must set up:

- 0 Server + Intro. Set up the IP address.
- 1 Channel 1 + Intro. To set up the port.
- 4 WLAN + Intro. Set up the network access.

```

Wifi - HyperTerminal
Archivo Edición Ver Llamar Transferir Ayuda

Change Setup:
0 Server
1 Channel 1
2 Channel 2
3 E-mail
4 WLAN
5 Expert
6 Security
7 Defaults
8 Exit without save
9 Save and exit      Your choice ? 0

Network mode: 0=Wired Only, 1=Wireless Only, 2=Bridging(One Host) (1) ?
IP Address : (010) .(030) .(090) .(011)
Set Gateway IP Address (Y) ?
Gateway IP addr ((010) .(030) .(090) .(200))
Netmask: Number of Bits for Host Part (0=default) (8)
Change telnet config password (N) ? _

00:05:56 conectado  ANSIV  9600 8-N-1  DESPLAZAR  MAY  NUM  Capturar  Imprimir
  
```

Example of
Server Set up

Ask your network administrator the IP and Gateway ad-

```

Wifi - HyperTerminal
Archivo Edición Ver Llamar Transferir Ayuda

Change Setup:
0 Server
1 Channel 1
2 Channel 2
3 E-mail
4 WLAN
5 Expert
6 Security
7 Defaults
8 Exit without save
9 Save and exit      Your choice ? 4

Topology: 0=Infrastructure, 1=Ad-Hoc (0) ?
Network name (SSID) (default) ?
Security suite: 0=none, 1=WEP, 2=WPA, 3=WPA2/802.11i (1) ?
Authentication: 0=open/none, 1=shared (0) ?
Encryption: 1=WEP64, 2=WEP128 (1) ?
Display current key (N) ?
Change Key (N) ?
TK Key index (1) ?
TX Data rate: 0=fixed, 1=auto fallback (1) ?
RX Data rate: 0=1, 1=2, 2=5.5, 3=11, 4=18, 5=24, 6=36, 7=54 Mbps (3) ?
Enable power management (N) ?

00:07:05 conectado  ANSIV  9600 8-N-1  DESPLAZAR  MAY  NUM  Capturar  Imprimir
  
```

Example of WLAN
Set up

Ask your network administrator the correct values

To exit select 8 (Exit without save) or 9 (Save and exit).

4.5 IP Address.

It is also possible to modify the IP address with the DeviceInstaller but this is only possible if the display IP address falls in the computer IP address. To assign an IP address the DeviceInstaller program from Lantronix must be used, which can be downloaded free from their website: www.lantronix.com

Select: Support.

Select: Latest version of DeviceInstaller.

Select to download the product: XPort.

Once the program is installed and running, press the Search button to locate the connected displays. The display must be turned on and connected to the network. If there are no network problems, a screen similar to this should be displayed.

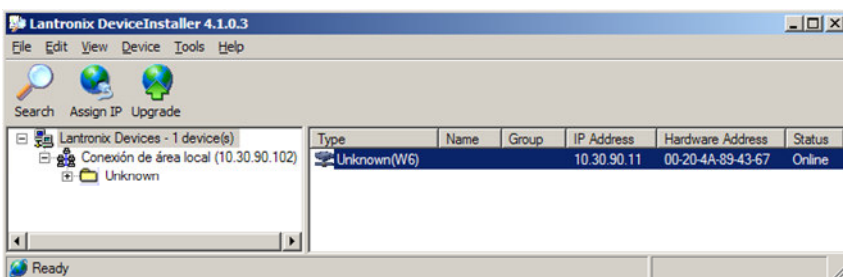

The IP address with which the equipment is supplied is: 10.30.90.11

The Hardware Address is the unit MAC code.

To assign the IP address you must first select the equipment by clicking on the XPort-03 to which you wish to assign the address. Then press Assign IP and follow the instructions.

IMPORTANT: All units are dispatched from the factory with the same IP address. Therefore to configure various units, they must be connected to the Ethernet and the address must be assigned one by one.

4.6 Modifying the port settings.

To modify the port configuration the DeviceInstaller program from Lantronix must be used, which can be downloaded free from their website: www.lantronix.com

Select: Support.

Select: Latest version of DeviceInstaller.

Select to download the product: XPort.

Once the program is installed and running, press the Search button to locate the connected displays. The display must be turned on and connected to the network. If there are no network problems, the same screen for configuring an IP address should be displayed. See section 4.5.

STATEMENT OF CONFORMITY



DISEÑOS Y TECNOLOGIA, S.A.
Poligon Industrial Les Guixeres
c/ Xarol 8C
08915 BADALONA Spain

As the builder of the equipment of the **DITEL** brand:
Numerical display with series connection.
Model : DT-203NW in all versions.
Model : DT-105NW in all versions.
Model : DT-106NW in all versions.
Model : DT-110NW in all versions.
Model : DT-111NW in all versions.

We declare under our sole responsibility that the aforementioned product complies with the following European directives:

Directive: 73/23/CEE Low Voltage Directive and addendum 93/68/CEE.
Standard UNE-EN61010-1 Security in electric equipment.

Directive: 89/336/CEE Electromagnetic Compatibility Directive and addendums 92/31/CEE and 93/68/CEE.
Standard UNE-EN 61000-6-4 Generic Emission Standard. Industrial environment.
Standard UNE-EN 61000-6-2 Generic Immunity Standard. Industrial environment.

Badalona, January 10, 2006

A handwritten signature in black ink, appearing to read 'J. Manel Edo', written over a horizontal line.

Josep Manel Edo
Technical Manager