

# Internal Calculation Value Data Address Map

Handles data dependent on an input range as an internal value before scaling (0.00 to 100.00%).

See "Operation Manual" for more details about individual parameter functions and settings ranges.

## Bit Data (read only): function code [02 (H)]

Relative address	Coil Number	Type	Memory contents	Read data	Dependent on range	Remarks/ related parameters
0000H	10001	bit	DO1 OUTPUT ON/OFF	0: DO1 OFF 1: DO1 ON		
00001H	10002	bit	DO2 OUTPUT ON/OFF	0: DO2 OFF 1: DO2 ON		
00002H	10003	bit	DO3 OUTPUT ON/OFF	0: DO3 OFF 1: DO3 ON		
00003H	10004	bit	DO4 OUTPUT ON/OFF	0: DO4 OFF 1: DO4 ON		
00004H	10005	bit	DO5 OUTPUT ON/OFF	0: DO5 OFF 1: DO5 ON		
00008H	10009	bit	DO1 Lamp ON/OFF	0: DO1 Lamp OFF 1: DO1 Lamp ON		
00009H	10010	bit	DO2 Lamp ON/OFF	0: DO2 Lamp OFF 1: DO2 Lamp ON		
0000AH	10011	bit	DO3 Lamp ON/OFF	0: DO3 Lamp OFF 1: DO3 Lamp ON		
0000BH	10012	bit	DO4 Lamp ON/OFF	0: DO4 Lamp OFF 1: DO4 Lamp ON		
0000CH	10013	bit	DO5 Lamp ON/OFF	0: DO5 Lamp OFF 1: DO5 Lamp ON		

## Word Data (read/write): function code [03 (H), 06 (H), 10 (H)]

### Operation (Ch1)

Parameter display	Parameter name	Contents	Relative address	Resistor Number		Type	Read data	Written data range	Factory Setting	Dependent on range
				Internal	Engineering unit					
"MAn"	MAn	Switches to manual mode	0084 <sub>H</sub>	40121	41121	Word	0: oFF (during auto) 1: on (during manual)	0: oFF (auto) 1: on (manual)	oFF	
"STbY"	STbY	Switches between RUN and standby	0003 <sub>H</sub>	40004	41004	Word	0: oFF (during RUN) 1: on (during standby)		oFF	
"rEM"	rEM	Switches to remote mode	0074 <sub>H</sub>	40117	41117	Word	0: LoCL (during Local) 1: rEM (during Remote)	0: LoCL (Local) 1: rEM (Remote)	LoCL	
"PrG"	PrG	Ramp/soak controls Command	0051 <sub>H</sub>	40082	41082	Word	0: oFF (during stop) 1: rUn (during run) 2: hLd (during hold)	0: oFF (stop) 1: rUn (run) 2: hLd (hold)	oFF	
"AT"	AT	Auto-tuning run command	0004 <sub>H</sub>	40005	41005	Word	0: oFF 1: rUn 2: Low		oFF	
"LACH"	LACH	Cancels the DO output latch Command	00A0 <sub>H</sub>	40161	41161	Word	0: oFF 1: rST (latch reset)		oFF	
"SvN" (note 1)	SvN	Selectable SV numbers	00DC <sub>H</sub>	40221	41221	Word	0: Sv0 (Local SV) 1: Sv1 (SV = SV-1) 2: Sv2 (SV = SV-2) 3: Sv3 (SV = SV-3) 4: Sv4 (SV = SV-4) 5: Sv5 (SV = SV-5) 6: Sv6 (SV = SV-6) 7: Sv7 (SV = SV-7) 8: di : SV = choose Di		Sv0	
"PLn I"	PLn1	Currently selected PID No.	00DD <sub>H</sub>	40222	41222	Word	0: Pid0 (PID group local) 1: Pid1 (PID group No. 1) 2: Pid2 (PID group No. 2) 3: Pid3 (PID group No. 3) 4: Pid4 (PID group No. 4) 5: Pid5 (PID group No. 5) 6: Pid6 (PID group No. 6) 7: Pid7 (PID group No. 7) 8: di (PID group Di selection)		Pid0	
"AL 1"	AL1	ALM1 set value or A1-L	00A2 <sub>H</sub>	40163	41163	Word	0% to 100% FS		10°C	○
"AL 1L"	AL1L	AL1L set value				Word	0% to 100% FS (absolute alarm) -100% to 100 % FS (deviation alarm)			○
"AL 1h"	AL1h	AL1h set value	00A3 <sub>H</sub>	40164	41164	Word	0% to 100% FS (absolute alarm) -100% to 100 % FS (deviation alarm)			○
"AL 2"	AL2	ALM2 set value or A2-L	00A9 <sub>H</sub>	40170	41170	Word	0% to 100% FS		10°C	○
"AL 2L"	AL2L	AL2L set value				Word	0% to 100% FS (absolute alarm) -100% to 100 % FS (deviation alarm)			○
"AL 2h"	AL2h	AL2h set value	00AA <sub>H</sub>	40171	41171	Word	0% to 100% FS (absolute alarm) -100% to 100 % FS (deviation alarm)			○
"AL 3"	AL3	ALM3 set value or A3-L	00B0 <sub>H</sub>	40177	41177	Word	0% to 100% FS		10°C	○
"AL 3L"	AL3L	AL3L set value				Word	0% to 100% FS (absolute alarm) -100% to 100 % FS (deviation alarm)			○
"AL 3h"	AL3h	AL3h set value	00B1 <sub>H</sub>	40178	41178	Word	0% to 100% FS (absolute alarm) -100% to 100 % FS (deviation alarm)			○

Note 1: If SV is changed using the front keys of the equipment and "SvN" is changed via communication at the same time, the SV set from the front panel may be reflected to the SV number changed via communication.

Parameter display	Parameter name	Contents	Relative address	Resistor Number		Type	Read data	Written data range	Factory Setting	Dependent on range
				Internal	Engineering unit					
"AL4"	AL4	ALM4 set value or A4-L	00B7H	40184	41184	Word	0% to 100% FS		10°C	○
"AL4L"	AL4L	AL4L set value				Word	0% to 100% FS (absolute alarm) -100% to 100 % FS (deviation alarm)		○	
"AL4h"	AL4h	AL4h set value	00B8H	40185	41185	Word	0% to 100% FS (absolute alarm) -100% to 100 % FS (deviation alarm)			○
"AL5"	AL5	ALM5 set value or A5-L	00BEH	40191	41191	Word	0% to 100% FS		10°C	○
"AL5L"	AL5L	AL5L set value				Word	0% to 100% FS (absolute alarm) -100% to 100 % FS (deviation alarm)		○	
"AL5h"	AL5h	AL5h set value	00BFH	40192	41192	Word	0% to 100% FS (absolute alarm) -100% to 100 % FS (deviation alarm)			○
"LoC"	LoC	Key lock	0027H	40040	41040	Word	0 : no lock 1 : all lock 2 : All but SV locked			

Note 1: If SV is changed using the front keys of the equipment and "SVn" is changed via communication at the same time, the SV set from the front panel may be reflected to the SV number changed via communication.

## PID (Ch2)

Parameter display	Parameter name	Contents	Relative address	Resistor Number		Type	Read data	Written data range	Factory Setting	Dependent on range
				Internal	Engineering unit					
"P"	P	Proportional band	0005H	40006	41006	Word	0 to 9999 (0.0% to 999.9%)	5.0%		
"I"	i	Integration time	0006H	40007	41007	Word	0 to 32000 (0 to 3200 sec)	240 sec		
"d"	d	Derivation time	0007H	40008	41008	Word	0 to 9999 (0.0 to 999.9sec)	60.0 sec		
"hYS"	hYS	ON/OFF control hysteresis	0008H	40009	41009	Word	0% to 50% FS	1°C		○
"CoL"	CoL	Cooling proportional band coefficient	0009H	40010	41010	Word	0 to 1000 (0.0 to 100.0)	1.0		
"db"	db	Dead band	000AH	40011	41011	Word	-5000 to 5000 (-50 to 50%)	0%		
"bAL"	bAL	Output convergence value	000CH	40013	41013	Word	-10000 to 10000 (-100 to 100%)	0/50 (single/dual)		
"Ar"	Ar	Anti-reset windup	000BH	40012	41012	Word	0% to 100% FS	100%		○
"rEv"	rEv	Sets normal/reverse operations	0057H	40088	41088	Word	0: rv-- (heat (reverse) / cool (none)) 1: no-- (heat (normal) / cool (none)) 2: rvno (heat (reverse) / cool (normal)) 3: norv (heat (normal) / cool (reverse)) 4: rvrv (heat (reverse) / cool (reverse)) 5: nono (heat (normal) / cool (normal))	rv--/rvno (single/ dual)		
"SvL"	SvL	SV limit (lower)	001EH	40031	41031	Word	0% to 100% FS	0% FS		○
"Svh"	Svh	SV limit (upper)	001FH	40032	41032	Word	0% to 100% FS	100% FS		○
"TC1"	TC1	OUT1 proportion cycle	0058H	40089	41089	Word	1 sec to 150 sec	30 or 2 sec		
"TC2"	TC2	OUT2 proportion cycle	0059H	40090	41090	Word	1 sec to 150 sec	30 or 3 sec		
"PLC1"	PLC1	OUT1 lower limit	0018H	40025	41025	Word	-300 to 10300 (-3.0 to 103.0%)	-3.0%		
"PhC1"	PhC1	OUT1 upper limit	0019H	40026	41026	Word	-300 to 10300 (-3.0 to 103.0%)	103.0%		
"PLC2"	PLC2	OUT2 lower limit	001AH	40027	41027	Word	-300 to 10300 (-3.0 to 103.0%)	-3.0%		
"PhC2"	PhC2	OUT2 upper limit	001BH	40028	41028	Word	-300 to 10300 (-3.0 to 103.0%)	103.0%		
"PCUT"	PCUT	Selects the output limiter type	0017H	40024	41024	Word	0 to 15	0		

**PID Palette (Ch3)**

Parameter display	Parameter name	Contents	Relative address	Resistor Number		Type	Read data	Written data range	Factory Setting	Dependent on range
				Internal	Engineering unit					
"Sv1"	Sv1	SV set value 1	00F0H	40241	41241	Word	0% to 100% FS	0% FS		○
"P1"	P1	Proportional band 1	00F1H	40242	41242	Word	0 to 9999 (0.0 to 999.9%)	5.0%		
"i1"	i1	Integration time 1	00F2H	40243	41243	Word	0 to 32000 (0 to 3200sec)	240 sec		
"d1"	d1	Derivation time 1	00F3H	40244	41244	Word	0 to 9999 (0.0 to 999.9sec)	60.0sec		
"hYS1"	hYS1	ON/OFF Control hysteresis 1	00F4H	40245	41245	Word	0% to 50% FS	1°C		○
"CoL1"	CoL1	Cooling proportional band 1	00F5H	40246	41246	Word	0 to 1000 (0.0 to 100.0)	1.0		
"db1"	db1	Dead band 1	00F6H	40247	41247	Word	-5000 to 5000 (-50.0 to 50.0%)	0%		
"bAL1"	bAL1	Output convergence value 1	00F7H	40248	41248	Word	-10000 to 10000 (-100.0 to 100.0%)	0/50 (single/dual)		
"Ar1"	Ar1	Anti-reset windup 1	00F8H	40249	41249	Word	0% to 100% FS	100% FS		○
"rEv1"	rEv1	Normal/Reverse setting 1	00F9H	40250	41250	Word	0: rv-- (heat (reverse) / cool (none)) 1: no-- (heat (normal) / cool (none)) 2: rvno (heat (reverse) / cool (normal)) 3: norv (heat (normal) / cool (reverse)) 4: rrvv (heat (reverse) / cool (reverse)) 5: nono (heat (normal) / cool (normal))	rv--/rvno (single/dual)		
"Sv2"	Sv2	SV set value 2	00FAH	40251	41251	Word	0% to 100% FS	0% FS		○
"P2"	P2	Proportional band 2	00FBH	40252	41252	Word	0 to 9999 (0.0 to 999.9%)	5.0%		
"i2"	i2	Integration time 2	00FCH	40253	41253	Word	0 to 32000 (0 to 3200sec)	240 sec		
"d2"	d2	Derivation time	00FDH	40254	41254	Word	0 to 9999 (0.0 to 999.9sec)	60.0sec		
"hYS2"	hYS2	ON/OFF control hysteresis 2	00FEH	40255	41255	Word	0% to 50% FS	1°C		○
"CoL2"	CoL2	Cooling proportional band 2	00FFH	40256	41256	Word	0 to 1000 (0.0 to 100.0)	1.0		
"db2"	db2	Dead band 2	0100H	40257	41257	Word	-5000 to 5000 (-50.0 to 50.0%)	0%		
"bAL2"	bAL2	Output convergence value 2	0101H	40258	41258	Word	-10000 to 10000 (-100.0 to 100.0%)	0/50 (single/dual)		
"Ar2"	Ar2	Anti-reset windup 2	0102H	40259	41259	Word	0% to 100% FS	100% FS		○
"rEv2"	rEv2	Normal/Reverse setting 2	0103H	40260	41260	Word	0: rv-- (heat (reverse) / cool (none)) 1: no-- (heat (normal) / cool (none)) 2: rvno (heat (reverse) / cool (normal)) 3: norv (heat (normal) / cool (reverse)) 4: rrvv (heat (reverse) / cool (reverse)) 5: nono (heat (normal) / cool (normal))	rv--/rvno (single/dual)		
"Sv3"	Sv3	SV set value 3	0104H	40261	41261	Word	0% to 100% FS	0% FS		○
"P3"	P3	Proportional band 3	0105H	40262	41262	Word	0 to 9999 (0.0 to 999.9%)	5.0%		

Parameter display	Parameter name	Contents	Relative address	Resistor Number		Type	Read data	Written data range	Factory Setting	Dependent on range
				Internal	Engineering unit					
"i4"	i3	Integration time 3	0106 <sub>H</sub>	40263	41263	Word	0 to 32000 (0 to 3200sec)	240 sec		
"d3"	d3	Derivation time 3	0107 <sub>H</sub>	40264	41264	Word	0 to 9999 (0.0 to 999.9sec)	60.0 sec		
"hYS3"	hYS3	ON/OFF control hysteresis 3	0108 <sub>H</sub>	40265	41265	Word	0% to 50% FS	1°C		○
"CoL3"	CoL3	Cooling proportional band 3	0109 <sub>H</sub>	40266	41266	Word	0 to 1000 (0.0 to 100.0)	1.0		
"db3"	db3	Dead band 3	010A <sub>H</sub>	40267	41267	Word	-5000 to 5000 (-50.0 to 50.0%)	0%		
"bAL3"	bAL3	Output convergence value 3	010B <sub>H</sub>	40268	41268	Word	-10000 to 10000 (-100.0 to 100.0%)	0/50 (single/dual)		
"Ar3"	Ar3	Anti-reset windup 3	010C <sub>H</sub>	40269	41269	Word	0% to 100% FS	100% FS		○
"rEv3"	rEv3	Normal/Reverse setting 3	010D <sub>H</sub>	40270	41270	Word	0: rv-- (heat (reverse) / cool (none)) 1: no-- (heat (normal) / cool (none)) 2: rvno (heat (reverse) / cool (normal)) 3: norv (heat (normal) / cool (reverse)) 4: rvrv (heat (reverse) / cool (reverse)) 5: nono (heat (normal) / cool (normal))	rv--/rvno (single/dual)		
"Sv4"	Sv4	SV set value 4	010E <sub>H</sub>	40271	41271	Word	0% to 100% FS	0% FS		○
"P4"	P4	Proportional band 4	010F <sub>H</sub>	40272	41272	Word	0 to 9999 (0.0 to 999.9%)	5.0%		
"i4"	i4	Integration time 4	0110 <sub>H</sub>	40273	41273	Word	0 to 32000 (0 to 3200sec)	240 sec		
"d4"	d4	Derivation time 4	0111 <sub>H</sub>	40274	41274	Word	0 to 9999 (0.0 to 999.9sec)	60.0sec		
"hYS4"	hYS4	ON/OFF control hysteresis 4	0112 <sub>H</sub>	40275	41275	Word	0% to 50% FS	1°C		○
"CoL4"	CoL4	Cooling proportional band 4	0113 <sub>H</sub>	40276	41276	Word	0 to 1000 (0.0 to 100.0)	1.0		
"db4"	db4	Dead band 4	0114 <sub>H</sub>	40277	41277	Word	-5000 to 5000 (-50.0 to 50.0%)	0%		
"bAL4"	bAL4	Output convergence value 4	0115 <sub>H</sub>	40278	41278	Word	-10000 to 10000 (-100.0 to 100.0%)	0/50 (single/dual)		
"Ar4"	Ar4	Anti-reset windup 4	0116 <sub>H</sub>	40279	41279	Word	0% to 100% FS	100% FS		○
"rEv4"	rEv4	Normal/Reverse setting 4	0117 <sub>H</sub>	40280	41280	Word	0: rv-- (heat (reverse) / cool (none)) 1: no-- (heat (normal) / cool (none)) 2: rvno (heat (reverse) / cool (normal)) 3: norv (heat (normal) / cool (reverse)) 4: rvrv (heat (reverse) / cool (reverse)) 5: nono (heat (normal) / cool (normal))	rv--/rvno (single/dual)		
"Sv5"	Sv5	SV set value 5	0118 <sub>H</sub>	40281	41281	Word	0% to 100% FS	0% FS		○
"P5"	P5	Proportional band 5	0119 <sub>H</sub>	40282	41282	Word	0 to 9999 (0.0 to 999.9%)	5.0%		
"i5"	i5	Integration time 5	011A <sub>H</sub>	40283	41283	Word	0 to 32000 (0 to 3200sec)	240 sec		
"d5"	d5	Derivation time 5	011B <sub>H</sub>	40284	41284	Word	0 to 9999 (0.0 to 999.9sec)	60.0sec		
"hYS5"	hYS5	ON/OFF control hysteresis 5	011C <sub>H</sub>	40285	41285	Word	0% to 50% FS	1°C		○
"CoL5"	CoL5	Cooling proportional band 5	011D <sub>H</sub>	40286	41286	Word	0 to 1000 (0.0 to 100.0)	1.0		
"db5"	db5	Dead band 5	011E <sub>H</sub>	40287	41287	Word	-5000 to 5000 (-50.0 to 50.0%)	0%		

Parameter display	Parameter name	Contents	Relative address	Resistor Number		Type	Read data	Written data range	Factory Setting	Dependent on range
				Internal	Engineering unit					
"bAL5"	bAL5	Output convergence value 5	011FH	40288	41288	Word	-10000 to 10000 (-100.0 to 100.0%)	0/50 (single/dual)		
"Ar5"	Ar5	Anti-reset windup 5	0120H	40289	41289	Word	0% to 100% FS	100% FS		○
"rEv5"	rEv5	Normal/Reverse setting 5	0121H	40290	41290	Word	0: rv-- (heat (reverse) / cool (none)) 1: no-- (heat (normal) / cool (none)) 2: rvno (heat (reverse) / cool (normal)) 3: norv (heat (normal) / cool (reverse)) 4: rvrv (heat (reverse) / cool (reverse)) 5: nono (heat (normal) / cool (normal))	rv--/rvno (single/dual)		
"Sv6"	Sv6	SV set value 6	0122H	40291	41291	Word	0% to 100% FS	0% FS		○
"P6"	P6	Proportional band 6	0123H	40292	41292	Word	0 to 9999 (0.0 to 999.9%)	5.0%		
"i6"	i6	Integration time 6	0124H	40293	41293	Word	0 to 32000 (0 to 3200sec)	240 sec		
"d6"	D6	Derivation time 6	0125H	40294	41294	Word	0 to 9999 (0.0 to 999.9sec)	60.0sec		
"hYS6"	hYS6	ON/OFF control hysteresis 6	0126H	40295	41295	Word	0% to 50% FS	1°C		○
"CoL6"	CoL6	Cooling proportional band 6	0127H	40296	41296	Word	0 to 1000 (0.0 to 100.0)	1.0		
"db6"	db6	Dead band 6	0128H	40297	41297	Word	-5000 to 5000 (-50.0 to 50.0%)	0%		
"bAL6"	bAL6	Output convergence value 6	0129H	40298	41298	Word	-10000 to 10000 (-100.0 to 100.0%)	0/50 (single/dual)		
"Ar6"	Ar6	Anti-reset windup 6	012AH	40299	41299	Word	0% to 100% FS	100% FS		○
"rEv6"	rEv6	Normal/Reverse setting 6	012BH	40300	41300	Word	0: rv-- (heat (reverse) / cool (none)) 1: no-- (heat (normal) / cool (none)) 2: rvno (heat (reverse) / cool (normal)) 3: norv (heat (normal) / cool (reverse)) 4: rvrv (heat (reverse) / cool (reverse)) 5: nono (heat (normal) / cool (normal))	rv--/rvno (single/dual)		
"Sv7"	Sv7	SV set value 7	012CH	40301	41301	Word	0% to 100% FS	0% FS		○
"P7"	P7	Proportional band 7	012DH	40302	41302	Word	0 to 9999 (0.0 to 999.9%)	5.0%		
"i7"	i7	Integration time 7	012EH	40303	41303	Word	0 to 32000 (0 to 3200sec)	240 sec		
"d7"	d7	Derivation time 7	012FH	40304	41304	Word	0 to 9999 (0.0 to 999.9sec)	60.0sec		
"hYS7"	hYS7	ON/OFF control hysteresis7	0130H	40305	41305	Word	0% to 50% FS	1°C		○
"CoL7"	CoL7	Cooling proportional band 7	0131H	40306	41306	Word	0 to 1000 (0.0 to 100.0)	1.0		
"db7"	db7	Dead band 7	0132H	40307	41307	Word	-5000 to 5000 (-50.0 to 50.0%)	0%		
"bAL7"	bAL7	Output convergence value 7	0133H	40308	41308	Word	-10000 to 10000 (-100.0 to 100.0%)	0/50 (single/dual)		
"Ar7"	Ar7	Anti-reset windup 7	0134H	40309	41309	Word	0% to 100% FS	100% FS		○

Parameter display	Parameter name	Contents	Relative address	Resistor Number		Type	Read data	Written data range	Factory Setting	Dependent on range
				Internal	Engineering unit					
"rEv7"	rEv7	Normal/Reverse setting 7	0135 <sub>H</sub>	40310	41310	Word	0: rv-- (heat (reverse) / cool (none)) 1: no-- (heat (normal) / cool (none)) 2: rvno (heat (reverse) / cool (normal)) 3: norv (heat (normal) / cool (reverse)) 4: rrvv (heat (reverse) / cool (reverse)) 5: nono (heat (normal) / cool (normal))	rv--/rvno (single/dual)		
"SvMH"	SvMX	Selectable SV numbers maximum	00DF <sub>H</sub>	40224	41224	Word	0: Sv0 (Local SV) 1: Sv1 (SV = SV-1) 2: Sv2 (SV = SV-2) 3: Sv3 (SV = SV-3) 4: Sv4 (SV = SV-4) 5: Sv5 (SV = SV-5) 6: Sv6 (SV = SV-6) 7: Sv7 (SV = SV-7) 8: di : SV = choose Di	Sv7		
"PL #"	PL1M	Selectable PID group maximum	00E0 <sub>H</sub>	40225	41225	Word	0: Pid0 (PID group local) 1: Pid1 (PID group No. 1) 2: Pid2 (PID group No. 2) 3: Pid3 (PID group No. 3) 4: Pid4 (PID group No. 4) 5: Pid5 (PID group No. 5) 6: Pid6 (PID group No. 6) 7: Pid7 (PID group No. 7) 8: di (PID group Di selection)	Pid7		

## Ramp/Soak (Ch4)

Parameter display	Parameter name	Contents	Relative address	Resistor Number		Type	Read data	Written data range	Factory Setting	Dependent on range
				Internal	Engineering unit					
"Pfn"	PTn	Ramp/Soak Activation Pattern	0230H	40561	41561	Word	0 (uses steps 1 to 4) 1 (uses steps 5 to 8) 2 (uses steps 1 to 8) 3 (uses steps 9 to 12) 4 (uses steps 13 to 16) 5 (uses steps 9 to 16) 6 (uses steps 1 to 16) 7 (according to DI)		6	
"TnU"	TiMU	Ramp/soak time units	0231H	40562	41562	Word	0 : hh.MM ( hour: min) 1 : MM.SS (min: sec)		hh.MM	
"Sv-1"	Sv-1	Ramp/Soak 1 seg/SV Set Value	0244H	40581	41581	Word	0% to 100% FS		0% FS	○
"Tn1r"	TM1r	Ramp/Soak 1 seg ramp time	0245H	40582	41582	Word	00.00-99.59 (hour:min/min: sec)		00.00 (hour:min)	
"Tn1S"	TM1S	Ramp/Soak 1 seg soak time	0246H	40583	41583	Word	00.00-99.59 (hour:min/min: sec)		00.00 (hour:min)	
"Sv-2"	Sv-2	Ramp/Soak 2 seg/SV Set Value	0247H	40584	41584	Word	0% to 100% FS		0% FS	○
"Tn2r"	TM2r	Ramp/Soak 2 seg ramp time	0248H	40585	41585	Word	00.00-99.59 (hour:min/min: sec)		00.00 (hour:min)	
"Tn2S"	TM2S	Ramp/Soak 2 seg soak time	0249H	40586	41586	Word	00.00-99.59 (hour:min/min: sec)		00.00 (hour:min)	
"Sv-3"	Sv-3	Ramp/Soak 3 seg/SV Set Value	024AH	40587	41587	Word	0% to 100% FS		0% FS	○
"Tn3r"	TM3r	Ramp/Soak 3 seg ramp time	024BH	40588	41588	Word	00.00-99.59 (hour:min/min: sec)		00.00 (hour:min)	
"Tn3S"	TM3S	Ramp/Soak 3 seg soak time	024CH	40589	41589	Word	00.00-99.59 (hour:min/min: sec)		00.00 (hour:min)	
"Sv-4"	Sv-4	Ramp/Soak 4 seg/SV Set Value	024DH	40590	41590	Word	0% to 100% FS		0% FS	○
"Tn4r"	TM4r	Ramp/Soak 4 seg ramp time	024EH	40591	41591	Word	00.00-99.59 (hour:min/min: sec)		00.00 (hour:min)	
"Tn4S"	TM4S	Ramp/Soak 4 seg soak time	024FH	40592	41592	Word	00.00-99.59 (hour:min/min: sec)		00.00 (hour:min)	
"Sv-5"	Sv-5	Ramp/Soak 5 seg/SV Set Value	0250H	40593	41593	Word	0% to 100% FS		0% FS	○
"Tn5r"	TM5r	Ramp/Soak 5 seg ramp time	0251H	40594	41594	Word	00.00-99.59 (hour:min/min: sec)		00.00 (hour:min)	
"Tn5S"	TM5S	Ramp/Soak 5 seg soak time	0252H	40595	41595	Word	00.00-99.59 (hour:min/min: sec)		00.00 (hour:min)	
"Sv-6"	Sv-6	Ramp/Soak 6 seg/SV Set Value	0253H	40596	41596	Word	0% to 100% FS		0% FS	○
"Tn6r"	TM6r	Ramp/Soak 6 seg ramp time	0254H	40597	41597	Word	00.00-99.59 (hour:min/min: sec)		00.00 (hour:min)	
"Tn6S"	TM6S	Ramp/Soak 6 seg soak time	0255H	40598	41598	Word	00.00-99.59 (hour:min/min: sec)		00.00 (hour:min)	
"Sv-7"	Sv-7	Ramp/Soak 7 seg/SV Set Value	0256H	40599	41599	Word	0% to 100% FS		0% FS	○
"Tn7r"	TM7r	Ramp/Soak 7 seg ramp time	0257H	40600	41600	Word	00.00-99.59 (hour:min/min: sec)		00.00 (hour:min)	
"Tn7S"	TM7S	Ramp/Soak 7 seg soak time	0258H	40601	41601	Word	00.00-99.59 (hour:min/min: sec)		00.00 (hour:min)	

Parameter display	Parameter name	Contents	Relative address	Resistor Number		Type	Read data	Written data range	Factory Setting	Dependent on range
				Internal	Engineering unit					
"Sv-8"	Sv-8	Ramp/Soak 8 seg/SV Set Value	0259H	40602	41602	Word	0% to 100% FS		0% FS	○
"r78r"	TM8r	Ramp/Soak 8 seg ramp time	025AH	40603	41603	Word	00.00-99.59 (hour:min/min: sec)		00.00 (hour:min)	
"r78S"	TM8S	Ramp/Soak 8 seg soak time	025BH	40604	41604	Word	00.00-99.59 (hour:min/min: sec)		00.00 (hour:min)	
"Sv-9"	Sv-9	Ramp/Soak 9 seg/SV Set Value	025CH	40605	41605	Word	0% to 100% FS		0% FS	○
"r79r"	TM9r	Ramp/Soak 9 seg ramp time	025DH	40606	41606	Word	00.00-99.59 (hour:min/min: sec)		00.00 (hour:min)	
"r79S"	TM9S	Ramp/Soak 9 seg soak time	025EH	40607	41607	Word	00.00-99.59 (hour:min/min: sec)		00.00 (hour:min)	
"Sv 10"	Sv10	Ramp/Soak 10 seg/SV Set Value	025FH	40608	41608	Word	0% to 100% FS		0% FS	○
"r 10r"	T10r	Ramp/Soak 10 seg ramp time	0260H	40609	41609	Word	00.00-99.59 (hour:min/min: sec)		00.00 (hour:min)	
"r 10S"	T10S	Ramp/Soak 10 seg soak time	0261H	40610	41610	Word	00.00-99.59 (hour:min/min: sec)		00.00 (hour:min)	
"Sv 11"	Sv11	Ramp/Soak 11 seg/SV Set Value	0262H	40611	41611	Word	0% to 100% FS		0% FS	○
"r 11r"	T11r	Ramp/Soak 11 seg ramp time	0263H	40612	41612	Word	00.00-99.59 (hour:min/min: sec)		00.00 (hour:min)	
"r 11S"	T11S	Ramp/Soak 11 seg soak time	0264H	40613	41613	Word	00.00-99.59 (hour:min/min: sec)		00.00 (hour:min)	
"Sv 12"	Sv12	Ramp/Soak 12 seg/SV Set Value	0265H	40614	41614	Word	0% to 100% FS		0% FS	○
"r 12r"	T12r	Ramp/Soak 12 seg ramp time	0266H	40615	41615	Word	00.00-99.59 (hour:min/min: sec)		00.00 (hour:min)	
"r 12S"	T12S	Ramp/Soak 12 seg soak time	0267H	40616	41616	Word	00.00-99.59 (hour:min/min: sec)		00.00 (hour:min)	
"Sv 13"	Sv13	Ramp/Soak 13 seg/SV Set Value	0268H	40617	41617	Word	0% to 100% FS		0% FS	○
"r 13r"	T13r	Ramp/Soak 13 seg ramp time	0269H	40618	41618	Word	00.00-99.59 (hour:min/min: sec)		00.00 (hour:min)	
"r 13S"	T13S	Ramp/Soak 13 seg soak time	026AH	40619	41619	Word	00.00-99.59 (hour:min/min: sec)		00.00 (hour:min)	
"Sv 14"	Sv14	Ramp/Soak 14 seg/SV Set Value	026BH	40620	41620	Word	0% to 100% FS		0% FS	○
"r 14r"	T14r	Ramp/Soak 14 seg ramp time	026CH	40621	41621	Word	00.00-99.59 (hour:min/min: sec)		00.00 (hour:min)	
"r 14S"	T14S	Ramp/Soak 14 seg soak time	026DH	40622	41622	Word	00.00-99.59 (hour:min/min: sec)		00.00 (hour:min)	
"Sv 15"	Sv15	(Ramp/Soak 15 seg/SV Set Value)	026EH	40623	41623	Word	0% to 100% FS		0% FS	○
"r 15r"	T15r	Ramp/Soak 15 seg ramp time	026FH	40624	41624	Word	00.00-99.59 (hour:min/min: sec)		00.00 (hour:min)	
"r 15S"	T15S	Ramp/Soak 15 seg soak time	0270H	40625	41625	Word	00.00-99.59 (hour:min/min: sec)		00.00 (hour:min)	
"Sv 16"	Sv16	Ramp/Soak 16 seg/SV Set Value	0271H	40626	41626	Word	0% to 100% FS		0% FS	○
"r 16r"	T16r	Ramp/Soak 16 seg ramp time	0272H	40627	41627	Word	00.00-99.59 (hour:min/min: sec)		00.00 (hour:min)	

Parameter display	Parameter name	Contents	Relative address	Resistor Number		Type	Read data	Written data range	Factory Setting	Dependent on range
				Internal	Engineering unit					
"f 16S"	T16S	Ramp/Soak 16 seg soak time	0273 <sub>H</sub>	40628	41628	Word	00.00-99.59 (hour:min/min: sec)	00.00 (hour:min)		
"Mod"	Mod	Ramp/soak mode	0050 <sub>H</sub>	40081	41081	Word	0 to 15	0		
"GSok"	GSok	Guaranty soak ON/OFF	023A <sub>H</sub>	40571	41571	Word	0:oFF (guaranty soak off) 1:on (guaranty soak on)	oFF		
"GS-L"	GS-L	Guaranty soak (lower limit)	023B <sub>H</sub>	40572	41572	Word	0% to 50% FS	5°C		○
"GS-h"	GS-h	Guaranty soak (upper limit)	023C <sub>H</sub>	40573	41573	Word	0% to 50% FS	5°C		○
"PvST"	PvST	PV start	023D <sub>H</sub>	40574	41574	Word	0:oFF (Not. PV start) 1:oN (PV start)	oFF		
"ConT"	ConT	Restore mode	023E <sub>H</sub>	40575	41575	Word	0:rES (Reset) 1:Con (Continue) 2:ini (Restart)	rES		
"PTnM"	PTnM	Sets the max pattern selection	0233 <sub>H</sub>	40564	41564	Word	0 to 7 (0 to 6 and di)	6		
"PMin"	PMin	Sets the min pattern selection	0234 <sub>H</sub>	40565	41565	Word	0 to 7 (0 to 6 and di)	0		

## Setup (Ch6)

Parameter display	Parameter name	Contents	Relative address	Resistor Number		Type	Read data	Written data range	Factory Setting	Dependent on range
				Internal	Engineering unit					
"P <sub>UV</sub> "	PvT	PV input type	000F <sub>H</sub>	40016	41016	Word	0 (JPT 100'3f) 1 (PT 100'3f) 2 (J) 3 (K) 4 (R) 5 (B) 6 (S) 7 (T) 8 (E) 9 (no function) 10 (no function) 11 (no function) 12 (N) 13 (PL- 2) 14 (no function) 15 (0V to 5V / 0mA to 20mA) 16 (1V to 5V/4mA to 20mA) 17 (0mV to 10V) 18 (2V to 10V) 19 (0mV to 100mV)	3 (K)		
"P <sub>Ub</sub> "	Pvb	PV input lower limit	0011 <sub>H</sub>	40018	41018	Word	-1999-9999	0°C		
"P <sub>UF</sub> "	PvF	PV input upper limit	0012 <sub>H</sub>	40019	41019	Word	-1999-9999	400°C		
"P <sub>Ud</sub> "	Pvd	Decimal position	0013 <sub>H</sub>	40020	41020	Word	0 (no decimal point) 1 (one decimal place) 2 (two decimal places)	0		
"P <sub>U</sub> "	PvU	Unit display	0010 <sub>H</sub>	40345	41345	Word	0: °C 1: °F	0		
"P <sub>UoF</sub> "	PvoF	PV input shift	000D <sub>H</sub>	40014	41014	Word	-10% to 10% FS	0% FS		
"S <sub>UoF</sub> "	SvoF	Sv shift	000E <sub>H</sub>	40015	41015	Word	-5000 to 5000 (-50.00% to 50.00% FS)			
"FF"	TF	PV input filter	0015 <sub>H</sub>	40022	41022	Word	0 to 1200 (0.0 to 120.0 sec)	5 sec		
"AdJ0"	AdJ0	PV display zero adjustment	0062 <sub>H</sub>	40099	41099	Word	-50% to 50% FS		○	
"AdJS"	AdJS	PV display Splan adjustment	0063 <sub>H</sub>	40100	41100	Word	-50% to 50% FS		○	
"rCJ"	rCJ	Cold Junction Compensation	0016 <sub>H</sub>	40023	41023	Word	0: oFF (off) 1: on (on)	on		
"rEM0"	rEM0	RSV zero adjustment	0075 <sub>H</sub>	40118	41118	Word	-50% to 50% FS	0%FS		
"rEMS"	rEMS	RSV span adjustment	0076 <sub>H</sub>	40119	41119	Word	-50% to 50% FS	0%		
"rEMr"	rEMr	RSV Input Range	0165 <sub>H</sub>	40358	41358	Word	0: 0-5v (0V to 5V) 1: 1-5v (1V to 5V)	1-5		
"rTF"	rTF	RSV input filter	0166 <sub>H</sub>	40359	41359	Word	0.0 sec to 120.0 sec	0.0 sec		
"C1r"	C1r	OUT1 range	017C <sub>H</sub>	40381	41381	Word	0: 0-5v (0V to 5V) 1: 1-5v (1V to 5V) 2: 0 to 10 (0V to 10V) 3: 2 to 10 (2V to 10V) 4: 0 to 20 (0mA to 20mA) 5: 4 to 20 (4mA to 20mA)	0 to 10 (voltage) 4 to 20 (current)		
"C2r"	C2r	OUT2 range	017D <sub>H</sub>	40382	41382	Word	0: 0-5v (0V to 5V) 1: 1-5v (1V to 5V) 2: 0 to 10 (0V to 10V) 3: 2 to 10 (2V to 10V) 4: 0 to 20 (0mA to 20mA) 5: 4 to 20 (4mA to 20mA)	0 to 10 (voltage) 4 to 20 (current)		

Parameter display	Parameter name	Contents	Relative address	Resistor Number		Type	Read data	Written data range	Factory Setting	Dependent on range
				Internal	Engineering unit					
"FLo1"	FLo1	Output 1 set value during FALT	0185 <sub>H</sub>	40390	41390	Word	-300 to 10300 (-3.00 to 103.00%)			
"FLo2"	FLo2	Output 2 set value during FALT	0186 <sub>H</sub>	40391	41391	Word	-300 to 10300 (-3.00 to 103.00%)			
"SFo1"	SFo1	Soft start OUT1 set value	0187 <sub>H</sub>	40392	41392	Word	-300 to 10300 (-3.00 to 103.00%)			
"SFTM"	SFTM	Soft start set time	0189 <sub>H</sub>	40394	41394	Word	00:00 to 99:59 (hour:min)		00:00 (hour:min)	
"Sbo1"	Sbo1	During standby, OUT1 set value	018D <sub>H</sub>	40398	41398	Word	-300 to 10300 (-3.00 to 103.00%)			
"Sbo2"	Sbo2	During standby, OUT2 set value	018E <sub>H</sub>	40399	41399	Word	-300 to 10300 (-3.00 to 103.00%)			
"SbMd"	SbMd	Standby mode setting	018F <sub>H</sub>	40400	41400	Word	0 to 7		0	
"AoT"	AoT	Types of AO output	0071 <sub>H</sub>	40114	41114	Word	0: PV 1: SV 2: MV 3: DV		PV	
"AoL"	AoL	AO lower limit scaling	0072 <sub>H</sub>	40115	41115	Word	-100% to 100%FS		0%	
"Aoh"	Aoh	AO upper limit scaling	0073 <sub>H</sub>	40116	41116	Word	-100% to 100%FS		100%	

## System (Ch7)

Parameter display	Parameter name	Contents	Relative address	Resistor Number		Type	Read data	Written data range	Factory Setting	Dependent on range
				Internal	Engineering unit					
"UKEY"	UKEY	USER key assignment settings	008C <sub>H</sub>	40141	41141	Word	0 (no function) 1 (Switches between STBY ON/OFF) 2 (Switches between Auto/Manual) 3 (Switches between Local/Remote) 4 (no function) 5 (Starts AT (standard)) 6 (Starts AT (low PV)) 7 (no function) 8 (Ramp SV HOLD) 9 (Ramp/soak RUN/OFF) 10 (Ramp/soak RUN/HOLD) 11 (no function) 12 (Latch cancel (all)) 13 (Latch cancel (DO1)) 14 (Latch cancel (DO2)) 15 (Latch cancel (DO3)) 16 (Latch cancel (DO4)) 17 (Latch cancel (DO5)) 18 (Start timer (DO1)) 19 (Start timer (DO2)) 20 (Start timer (DO3)) 21 (Start timer (DO4)) 22 (Start timer (DO5)) 23 (SV No. + 1 (send)) 24 (PID No. + 1 (send)) 25 (no function) 26 (Ramp/soak Pattern No. + 1 (send)) 27 (SV No. + 1, PID No. + 1 (send))		2	

Parameter display	Parameter name	Contents	Relative address	Resistor Number		Type	Read data	Written data range	Factory Setting	Dependent on range
				Internal	Engineering unit					
"dL1"	di1	DI-1 function select	008EH	40143	41143	Word	0 (no function) 1 (Switches between STBY ON/OFF) 2 (Switches between Auto/Manual) 3 (Switches between Local/Remote) 4 (Switches EXMV1) 5 (no function) 6 (Starts AT (standard)) 7 (Starts AT (low PV)) 8 (no function) 9 (no function) 10 (Ramp SV ON/OFF) 11 (Ramp SV HOLD) 12 (Ramp/soak OFF) 13 (Ramp/soak RUN/HOLD) 14 (no function) 15 (Latch cancel (all)) 16 (Latch cancel (DO1)) 17 (Latch cancel (DO2)) 18 (Latch cancel (DO3)) 19 (Latch cancel (DO4)) 20 (Latch cancel (DO5)) 21 (Start timer (DO1)) 22 (Start timer (DO2)) 23 (Start timer (DO3)) 24 (Start timer (DO4)) 25 (Start timer (DO5)) 26 (SV No. 1) 27 (SV No. 2) 28 (SV No. + 4) 29 (PID No. +1) 30 (PID No. +2) 31 (PID No. + 4) 32 (no function) 33 (no function) 34 (no function) 35 (SV No.+1, PID No. +1) 36 (SV No.+2, PID No. +2) 37 (SV No.+4, PID No. +4) 38 (Pattern No.+1) 39 (Pattern No.+2) 40 (Pattern No.+4) 41 (DI Soft start) 42 (Ramp soak RUN) 43 (Ramp soak HOLD) 44 (Ramp soak RUN at DO1 startup) 45 (Ramp soak RUN at DO2 startup) 46 (Ramp soak RUN at DO3 startup) 47 (Ramp soak RUN at DO4 startup) 48 (Ramp soak RUN at DO5 startup)	0		
"dL2"	di2	DI-2 function select	008FH	40144	41144	Word	Same as above	0		
"dL3"	di3	DI-3 function select	0090H	40145	41145	Word	Same as above	0		
"dL4"	di4	DI-4 function select	0091H	40146	41146	Word	Same as above	0		
"dL5"	di5	DI-5 function select	0092H	40147	41147	Word	Same as above	0		
"do1f"	do1T	DO1 output event type setting	0028H	40041	41041	Word	0-102	0		
"doP1"	doP1	Sets DO1 option function	00A5H	40166	41166	Word	0000 to 1111	0		
"do2f"	do2T	DO2 output event type setting	0029H	40042	41042	Word	0 to 102	0		
"doP2"	doP2	DO5 option function setting	00ACH	40173	41173	Word	0000 to 1111	0		
"do3f"	do3T	DO3 output event type setting	002AH	40043	41043	Word	0 to 102	0		

Parameter display	Parameter name	Contents	Relative address	Resistor Number		Type	Read data	Written data range	Factory Setting	Dependent on range
				Internal	Engineering unit					
"doP3"	doP3	DO3 option function setting	00B3H	40180	41180	Word	0000 to 1111		0	
"do4I"	do4T	DO4 output event type setting	00B6H	40183	41183	Word	0 to 102		0	
"doP4"	doP4	DO4 option function setting	00BAH	40187	41187	Word	0000 to 1111		0	
"do5I"	do5T	DO5 output event type setting	00BDH	40190	41190	Word	0 to 102		0	
"doP5"	doP5	DO5 option function setting	00C1H	40194	41194	Word	0000 to 1111		0	
"rMP"	rMP	Ramp SV effect/no effect	01ACH	40429	41429	Word	oFF:no effect   ON:effect		on	
"rMPL"	rMPL	Ramp SV - Decline	01ACH	40430	41430	Word	0% to 100% FS/°C		0°C	○
"rMPH"	rMPH	Ramp SV - Incline	01ADH	40431	41431	Word	0% to 100% FS/°C		0°C	○
"rMPU"	rMPU	Ramp SV slope time unit	01AFH	40432	41432	Word	0: hour (slope temperature/hour) 1: Min (slope temperature/min)		hoUr	
"SvT"	SvT	Ramp SV - SV display mode selection	01B0H	40433	41433	Word	0: rMP (Ramp SV HOLD) 1: TrG (target SV)		rMP	
"CTrL"	CTrL	Control methods	0001H	40002	41002	Word	0: PiD (PID control) 1: FUZY (Fuzzy Pid control) 2: SELF (Self-tuning control) 3: PiD2 (Pid2 control)			
"PrCS"	PrCS	Control target	01A7H	40424	41424	Word	0: SRV1 (Servo control 1) 1: SRV2 (Servo control 2) 2: PFb (Position feedback control)		PFb/Srv1 (PFb on/PFb off)	
"STMd"	STMd	Startup mode	01B1H	40434	41434	Word	0: Auto (starts up in auto mode) 1: MAn (starts up in manual mode) 2: Rem (start in the remote mode) 3: STby (start in the standby mode)		Auto	

### Alarm (Ch8)

Parameter display	Parameter name	Contents	Relative address	Resistor Number		Type	Read data	Written data range	Factory Setting	Dependent on range
				Internal	Engineering unit					
"A1hY"	A1hY	ALM1 hysteresis	0031H	40050	41050	Word	0% to 50% FS		1°C	○
"dLY1"	dLY1	ALM1 delay	0034H	40053	41053	Word	0-9999 [sec/min]		0	
"dL1U"	dL1U	ALM1 delay time units	00A7H	40168	41168	Word	0: sec 1: Min			
"A2hY"	A2hY	ALM2 hysteresis	0032H	40051	41051	Word	0% to 50% FS		1°C	○
"dLY2"	dLY2	ALM2 delay	0035H	40054	41054	Word	0 to 9999 [sec/min]		0	
"dL2U"	dL2U	ALM2 delay time units	00AEH	40175	41175	Word	0: sec 1: Min			
"A3hY"	A3hY	ALM3 hysteresis	0033H	40052	41052	Word	0% to 50% FS		1°C	○
"dLY3"	dLY3	ALM3 delay	0036H	40055	41055	Word	0 to 9999 [sec/min]		0	
"dL3U"	dL3U	ALM3 delay time units	00B5H	40182	41182	Word	0: sec 1: Min			
"A4hY"	A4hY	ALM4 hysteresis	00B9H	40186	41186	Word	0% to 50% FS		1°C	○
"dLY4"	dLY4	ALM4 delay	00BBH	40188	41188	Word	0 to 9999 [sec/min]		0	
"dL4U"	dL4U	ALM4 delay time units	00BCH	40189	41189	Word	0: sec 1: Min			
"A5hY"	A5hY	ALM5 hysteresis	00C0H	40193	41193	Word	0% to 50% FS		1°C	○
"dLY5"	dLY5	ALM5 delay	00C2H	40195	41195	Word	0 to 9999 [sec/min]		0	

Parameter display	Parameter name	Contents	Relative address	Resistor Number		Type	Read data	Written data range	Factory Setting	Dependent on range
				Internal	Engineering unit					
"dL5U"	dL5U	ALM1 delay time units	00C3 <sub>H</sub>	40196	41196	Word	0: sec 1: Min			
"hb l"	hb1	HB Alarm Set Value	0026 <sub>H</sub>	40039	41039	Word	0 to 500 (0.0 to 50.0 (A))			
"hb lh"	hb1h	HB alarm hysteresis	00C5 <sub>H</sub>	40198	41198	Word	0 to 500 (0.0 to 50.0 (A))			
"hS l"	hS1	Load short-circuit alarm setting value	00C6 <sub>H</sub>	40199	41999	Word	0 to 500 (0.0 to 50.0 (A))		0.0A	
"hS lh"	hS1h	Load short-circuit alarm hysteresis	00C7 <sub>H</sub>	40200	41200	Word	0 to 500 (0.0 to 50.0 (A))		0.5A	
"LbTm"	LbTM	Loop break detection time	00CC <sub>H</sub>	40205	41205	Word	0 sec to 9999 sec		0 sec	
"LbAb"	LbAb	Loop break detection range	00CD <sub>H</sub>	40206	41206	Word	0 to 10000 (0% to 100% FS)		0 sec	○

### PFB (Ch10)

Parameter display	Parameter name	Contents	Relative address	Resistor Number		Type	Read data	Written data range	Factory Setting	Dependent on range
				Internal	Engineering unit					
"PGAP"	PGAP	PFB dead band	01A8 <sub>H</sub>	40425	41425	Word	0.0 to 100.0%		5%	○
"TrvL"	TrvL	Valve Stroke Time	01A9 <sub>H</sub>	40426	41426	Word	5 sec to 180 sec		30 sec	
"CAL"	CAL	PFB Input Adjustment Command	01AB <sub>H</sub>	40428	41428	Word	0 (none/forcible termination) 1 (zero adjustment) 2 (span adjustment) 3 (automatic adjustment)	0 (none/forcible termination) 1 (zero adjustment) 2 (span adjustment) 3 (automatic adjustment)	-	

### Password Setup (Ch11)

Parameter display	Parameter name	Contents	Relative address	Resistor Number		Type	Read data	Written data range	Factory Setting	Dependent on range
				Internal	Engineering unit					
"PAS1"	PAS1	Password1 setup	0209 <sub>H</sub>	40522	41522	Word	-32768 to 32767 (8000 to 7FFF)		0	
"PAS2"	PAS2	Password2 setup	020A <sub>H</sub>	40523	41523	Word	-32768 to 32767 (8000 to 7FFF)		0	
"PAS3"	PAS3	Password3 setup	020B <sub>H</sub>	40524	41524	Word	-32768 to 32767 (8000 to 7FFF)		0	

## Display (Ch12)

Parameter display	Parameter name	Contents	Relative address	Resistor Number		Type	Read data	Written data range	Factory Setting	Dependent on range
				Internal	Engineering unit					
"dP01"	dP01	Parameter display mask	01C2H	40451	41451	Word	-32768 to 32767 (8000 to 7FFF)		Different depending on model code.	
"dP02"	dP02	Parameter display mask	01C3H	40452	41452	Word	-32768 to 32767 (8000 to 7FFF)		Different depending on model code.	
"dP03"	dP03	Parameter display mask	01C4H	40453	41453	Word	-32768 to 32767 (8000 to 7FFF)		Different depending on model code.	
"dP04"	dP04	Parameter display mask	01C5H	40454	41454	Word	-32768 to 32767 (8000 to 7FFF)		Different depending on model code.	
"dP05"	dP05	Parameter display mask	01C6H	40455	41455	Word	-32768 to 32767 (8000 to 7FFF)		Different depending on model code.	
"dP06"	dP06	Parameter display mask	01C7H	40456	41456	Word	-32768 to 32767 (8000 to 7FFF)		Different depending on model code.	
"dP07"	dP07	Parameter display mask	01C8H	40457	41457	Word	-32768 to 32767 (8000 to 7FFF)		Different depending on model code.	
"dP08"	dP08	Parameter display mask	01C9H	40458	41458	Word	-32768 to 32767 (8000 to 7FFF)		Different depending on model code.	
"dP09"	dP09	Parameter display mask	01CAH	40459	41459	Word	-32768 to 32767 (8000 to 7FFF)		Different depending on model code.	
"dP10"	dP10	Parameter display mask	01CBH	40460	41460	Word	-32768 to 32767 (8000 to 7FFF)		Different depending on model code.	
"dP11"	dP11	Parameter display mask	01CCH	40461	41461	Word	-32768 to 32767 (8000 to 7FFF)		Different depending on model code.	
"dP12"	dP12	Parameter display mask	01CDH	40462	41462	Word	-32768 to 32767 (8000 to 7FFF)		Different depending on model code.	
"dP13"	dP13	Parameter display mask	01CEH	40463	41463	Word	-32768 to 32767 (8000 to 7FFF)		Different depending on model code.	
"dP14"	dP14	Parameter display mask	01CFH	40464	41464	Word	-32768 to 32767 (8000 to 7FFF)		Different depending on model code.	
"dP15"	dP15	Parameter display mask	01D0H	40465	41465	Word	-32768 to 32767 (8000 to 7FFF)		Different depending on model code.	
"dP16"	dP16	Parameter display mask	01D1H	40466	41466	Word	-32768 to 32767 (8000 to 7FFF)		Different depending on model code.	
"dP17"	dP17	Parameter display mask	01D2H	40467	41467	Word	-32768 to 32767 (8000 to 7FFF)		Different depending on model code.	
"dP18"	dP18	Parameter display mask	01D3H	40468	41468	Word	-32768 to 32767 (8000 to 7FFF)		Different depending on model code.	
"dP19"	dP19	Parameter display mask	01D4H	40469	41469	Word	-32768 to 32767 (8000 to 7FFF)		Different depending on model code.	
"dP20"	dP20	Parameter display mask	01D5H	40470	41470	Word	-32768 to 32767 (8000 to 7FFF)		Different depending on model code.	
"dP21"	dP21	Parameter display mask	01D6H	40471	41471	Word	-32768 to 32767 (8000 to 7FFF)		Different depending on model code.	
"dP22"	dP22	Parameter display mask	01D7H	40472	41472	Word	-32768 to 32767 (8000 to 7FFF)		Different depending on model code.	
"dP23"	dP23	Parameter display mask	01D8H	40473	41473	Word	-32768 to 32767 (8000 to 7FFF)		Different depending on model code.	
"dP24"	dP24	Parameter display mask	01D9H	40474	41474	Word	-32768 to 32767 (8000 to 7FFF)		Different depending on model code.	
"dP25"	dP25	Parameter display mask	01DAH	40475	41475	Word	-32768 to 32767 (8000 to 7FFF)		Different depending on model code.	

Parameter display	Parameter name	Contents	Relative address	Resistor Number		Type	Read data	Written data range	Factory Setting	Dependent on range
				Internal	Engineering unit					
"dP26"	dP26	Parameter display mask	01DB <sub>H</sub>	40476	41476	Word	-32768 to 32767 (8000 to 7FFF)		Different depending on model code.	
"dP27"	dP27	Parameter display mask	01DC <sub>H</sub>	40477	41477	Word	-32768 to 32767 (8000 to 7FFF)		Different depending on model code.	
"dP28"	dP28	Parameter display mask	01DD <sub>H</sub>	40478	41478	Word	-32768 to 32767 (8000 to 7FFF)		Different depending on model code.	
"dP29"	dP29	Parameter display mask	01DE <sub>H</sub>	40479	41479	Word	-32768 to 32767 (8000 to 7FFF)		Different depending on model code.	
"dP30"	dP30	Parameter display mask	01DF <sub>H</sub>	40480	41480	Word	-32768 to 32767 (8000 to 7FFF)		Different depending on model code.	

### Other

Parameter display	Parameter name	Contents	Relative address	Resistor Number		Type	Read data	Written data range	Factory Setting	Dependent on range
				Internal	Engineering unit					
SV	Front SV set value	Front SV set value	0002 <sub>H</sub>	40003	41003	Word	0 to 10000 (in the 0% to 100% FS set value limit)			○
			0082 <sub>H</sub>	40131	41131	Word				
MV	Front MV set value	Front MV set value	0079 <sub>H</sub>	40122	41122	Word	-300 to 10300 (-3.0 to 103.0%)			
			0083 <sub>H</sub>	40132	41132	Word				

## Resistor Number Order Read/Write Parameter List

Relative address	Resistor Number		Parameter contents
	Internal	Engineering unit	
0001 <sub>H</sub>	40002	41002	CTrL (control method)
0002 <sub>H</sub>	40003	41003	Front SV set value
0003 <sub>H</sub>	40004	41004	STbY (Switches between RUN and standby)
0004 <sub>H</sub>	40005	41005	AT (Auto-tuning run command)
0005 <sub>H</sub>	40006	41006	P (Proportional band)
0006 <sub>H</sub>	40007	41007	i (Integration time)
0007 <sub>H</sub>	40008	41008	d (Derivation time)
0008 <sub>H</sub>	40009	41009	hYS (ON/OFF control hysteresis)
0009 <sub>H</sub>	40010	41010	CoL (Cooling proportional band coefficient)
000A <sub>H</sub>	40011	41011	db (Dead band)
000B <sub>H</sub>	40012	41012	Ar (Anti-reset windup)
000C <sub>H</sub>	40013	41013	bAL (output convergence value)
000D <sub>H</sub>	40014	41014	PvoF (PV input shift)
000E <sub>H</sub>	40015	41015	SvoF (SV input shift)
000F <sub>H</sub>	40016	41016	PvT (PV input types)
0010 <sub>H</sub>	40017	41017	P-F (Unit display)
0011 <sub>H</sub>	40018	41018	Pvb (PV input lower limit)
0012 <sub>H</sub>	40019	41019	PvF (PV input upper limit)
0013 <sub>H</sub>	40020	41020	Pvd (decimal position)
0014 <sub>H</sub>	40021	41021	-
0015 <sub>H</sub>	40022	41022	TF (PV input filter)
0016 <sub>H</sub>	40023	41023	rCJ (Cold junction compensation)
0017 <sub>H</sub>	40024	41024	PCUT (Selects the output limiter type)
0018 <sub>H</sub>	40025	41025	PLC1 (OUT1 lower limit)
0019 <sub>H</sub>	40026	41026	PhC1 (OUT1 upper limit)
001A <sub>H</sub>	40027	41027	PLC2 (OUT2 lower limit)
001B <sub>H</sub>	40028	41028	PhC2 (OUT2 upper limit)
001E <sub>H</sub>	40031	41031	SvL (SV limit (lower))
001F <sub>H</sub>	40032	41032	Svh (SV limit (upper))
0026 <sub>H</sub>	40039	41039	hb1 (CT HB alarm set value)
0027 <sub>H</sub>	40040	41040	LoC (Key lock)
0028 <sub>H</sub>	40041	41041	do1T (DO1 output event type)
0029 <sub>H</sub>	40042	41042	do2T (DO2 output event type)
002A <sub>H</sub>	40043	41043	do3T (DO3 output event type)
002B <sub>H</sub>	40044	41044	AL1 (ALM1 set value) or A1-L
002C <sub>H</sub>	40045	41045	AL2 (ALM2 set value) or A2-L
002D <sub>H</sub>	40046	41046	AL3 (ALM3 set value) or A3-L
002E <sub>H</sub>	40047	41047	A1-h (Alarm 1 upper limit set value)
002F <sub>H</sub>	40048	41048	A2-h (Alarm 2 upper limit set value)
0030 <sub>H</sub>	40049	41049	A3-h (Alarm 3 upper limit set value)
0031 <sub>H</sub>	40050	41050	A1hY (ALM1 hysteresis)
0032 <sub>H</sub>	40051	41051	A2hY (ALM2 hysteresis)
0033 <sub>H</sub>	40052	41052	A3hY (ALM3 hysteresis)
0034 <sub>H</sub>	40053	41053	dLY1 (ALM1 delay)
0035 <sub>H</sub>	40054	41054	dLY2 (ALM2 delay)
0036 <sub>H</sub>	40055	41055	dLY3 (ALM3 delay)

Relative address	Resistor Number		Parameter contents
	Internal	Engineering unit	
0038 <sub>H</sub>	40057	41057	Sv-1 (Ramp/soak 1 seg/SV set value)
0039 <sub>H</sub>	40058	41058	Sv-2 (Ramp/soak 2 seg/SV set value)
003A <sub>H</sub>	40059	41059	Sv-3 (Ramp/soak 3 seg/SV set value)
003B <sub>H</sub>	40060	41060	Sv-4 (Ramp/soak 4 seg/SV set value)
003C <sub>H</sub>	40061	41061	Sv-5 (Ramp/soak 5 seg/SV set value)
003D <sub>H</sub>	40062	41062	Sv-6 (Ramp/soak 6 seg/SV set value)
003E <sub>H</sub>	40063	41063	Sv-7 (Ramp/soak 7 seg/SV set value)
003F <sub>H</sub>	40064	41064	Sv-8 (Ramp/soak 8 seg/SV set value)
0040 <sub>H</sub>	40065	41065	TM1r (Ramp/soak 1 seg ramp time)
0041 <sub>H</sub>	40066	41066	TM1S (Ramp/soak 1 seg soak time)
0042 <sub>H</sub>	40067	41067	TM2r (Ramp/soak 2 seg ramp time)
0043 <sub>H</sub>	40068	41068	TM2S (Ramp/soak 2 seg soak time)
0044 <sub>H</sub>	40069	41069	TM3r (Ramp/soak 3 seg ramp time)
0045 <sub>H</sub>	40070	41070	TM3S (Ramp/soak 3 seg soak time)
0046 <sub>H</sub>	40071	41071	TM4r (Ramp/soak 4 seg ramp time)
0047 <sub>H</sub>	40072	41072	TM4S (Ramp/soak 4 seg soak time)
0048 <sub>H</sub>	40073	41073	TM5r (Ramp/soak 5 seg ramp time)
0049 <sub>H</sub>	40074	41074	TM5S (Ramp/soak 5 seg soak time)
004A <sub>H</sub>	40075	41075	TM6r (Ramp/soak 6 seg ramp time)
004B <sub>H</sub>	40076	41076	TM6S (Ramp/soak 6 seg soak time)
004C <sub>H</sub>	40077	41077	TM7r (Ramp/soak 7 seg ramp time)
004D <sub>H</sub>	40078	41078	TM7S (Ramp/soak 7 seg soak time)
004E <sub>H</sub>	40079	41079	TM8r (Ramp/soak 8 seg ramp time)
004F <sub>H</sub>	40080	41080	TM8S (Ramp/soak 8 seg soak time)
0050 <sub>H</sub>	40081	41081	Mod (Ramp/soak mode)
0051 <sub>H</sub>	40082	41082	PrG (PROG) (Ramp/soak control command)
0052 <sub>H</sub>	40083	41083	PTn (Ramp/soak activation pattern)
0054 <sub>H</sub>	40085	41085	SLFb (Pv stable width during self-tuning)
0056 <sub>H</sub>	40087	41087	Communication DI
0057 <sub>H</sub>	40088	41088	rEv (Sets normal/reverse operations)
0058 <sub>H</sub>	40089	41089	TC1 (OUT1 proportion cycle)
0059 <sub>H</sub>	40090	41090	TC2 (OUT2 proportion cycle)
005B <sub>H</sub>	40092	41092	A1oP (Alarm 1 option function)
005C <sub>H</sub>	40093	41093	A2oP (Alarm 2 option function)
005D <sub>H</sub>	40094	41094	A3oP (Alarm 3 option function)
005E <sub>H</sub>	40095	41095	DI-1 operation setting
005F <sub>H</sub>	40096	41096	DI-2 operation setting
0060 <sub>H</sub>	40097	41097	onoF (Hysteresis mode setting)
0062 <sub>H</sub>	40099	41099	AdJ0 (PV display zero adjustment)
0063 <sub>H</sub>	40100	41100	AdJS (PV display Splan adjustment)
0071 <sub>H</sub>	40114	41114	AoT (AO output type)
0072 <sub>H</sub>	40115	41115	AoL (AO lower limit scaling)
0073 <sub>H</sub>	40116	41116	Aoh (AO upper limit scaling)
0074 <sub>H</sub>	40117	41117	rEM (CMOD) (switching remote mode)
0075 <sub>H</sub>	40118	41118	rEMO (RSV zero adjustment)
0076 <sub>H</sub>	40119	41119	rEMS (RSV span adjustment)

Relative address	Resistor Number		Parameter contents
	Internal	Engineering unit	
0077 <sub>H</sub>	40120	41120	rTF (RSV input filter)
0078 <sub>H</sub>	40121	41121	MAn (switching manual mode)
0079 <sub>H</sub>	40122	41122	Front MV set value
0082 <sub>H</sub>	40131	41131	Front SV set value
0083 <sub>H</sub>	40132	41132	Front MV set value
0084 <sub>H</sub>	40133	41133	MAn (switching manual mode)
0085 <sub>H</sub>	40134	41134	STbY (Switches between RUN and standby)
0086 <sub>H</sub>	40135	41135	AT (Auto-tuning run command)
0087 <sub>H</sub>	40136	41136	rEM (switching remote mode)
008C <sub>H</sub>	40141	41141	UKEY (USER key allocation settings)
008E <sub>H</sub>	40143	41143	di-1 (DI-1 function selection)
008F <sub>H</sub>	40144	41144	di-2 (DI-2 function selection)
0090 <sub>H</sub>	40145	41145	di-3 (DI-3 function selection)
0091 <sub>H</sub>	40146	41146	di-4 (DI-4 function selection)
0092 <sub>H</sub>	40147	41147	di-5 (DI-5 function selection)
00A0 <sub>H</sub>	40161	41161	LACH (DO output latch cancel command)
00A1 <sub>H</sub>	40162	41162	do1T (DO1 output event type)
00A2 <sub>H</sub>	40163	41163	AL1L (AL1 set value)
00A3 <sub>H</sub>	40164	41164	AL1h (AL1h set value)
00A4 <sub>H</sub>	40165	41165	A1hY (ALM1 hysteresis)
00A5 <sub>H</sub>	40166	41166	doP1 (Sets DO1 option function)
00A6 <sub>H</sub>	40167	41167	dLY1 (ALM1 delay)
00A7 <sub>H</sub>	40168	41168	dL1U (ALM1 delay time units)
00A8 <sub>H</sub>	40169	41169	do2T (DO2 output event type)
00A9 <sub>H</sub>	40170	41170	AL2L (AL2 set value)
00AA <sub>H</sub>	40171	41171	AL2h (AL2h set value)
00AB <sub>H</sub>	40172	41172	A2hY (ALM2 hysteresis)
00AC <sub>H</sub>	40173	41173	doP2 (DO2 option function setting)
00AD <sub>H</sub>	40174	41174	dLY2 (ALM2 delay)
00AE <sub>H</sub>	40175	41175	dL2U (ALM2 delay time units)
00AF <sub>H</sub>	40176	41176	do3T (DO3 output event type)
00B0 <sub>H</sub>	40177	41177	AL3L (AL3 set value)
00B1 <sub>H</sub>	40178	41178	AL3h (AL3h set value)
00B2 <sub>H</sub>	40179	41179	A3hY (ALM3 hysteresis)
00B3 <sub>H</sub>	40180	41180	doP3 (DO3 option function setting)
00B4 <sub>H</sub>	40181	41181	dLY3 (ALM3 delay)
00B5 <sub>H</sub>	40182	41182	dL3U (ALM3 delay time units)
00B6 <sub>H</sub>	40183	41183	do4T (DO4 output event type)
00B7 <sub>H</sub>	40184	41184	AL4L (AL4 set value)
00B8 <sub>H</sub>	40185	41185	AL4h (AL4h set value)
00B9 <sub>H</sub>	40186	41186	A4hY (ALM4 hysteresis)
00BA <sub>H</sub>	40187	41187	do4P (DO4 option function setting)
00BB <sub>H</sub>	40188	41188	dLY4 (ALM4 delay)
00BC <sub>H</sub>	40189	41189	dL4U (ALM4 delay time units)
00BD <sub>H</sub>	40190	41190	do5T (DO5 output event type)
00BE <sub>H</sub>	40191	41191	AL5L (AL5 set value)

Relative address	Resistor Number		Parameter contents
	Internal	Engineering unit	
00BF <sub>H</sub>	40192	41192	AL5h (AL5h set value)
00C0 <sub>H</sub>	40193	41193	A5hY (ALM5 hysteresis)
00C1 <sub>H</sub>	40194	41194	doP5 (Sets DO5 option function)
00C2 <sub>H</sub>	40195	41195	dLY5 (ALM5 delay)
00C3 <sub>H</sub>	40196	41196	dL5U (ALM5 delay time units)
00C4 <sub>H</sub>	40197	41197	hb1 (CT HB alarm set value)
00C6 <sub>H</sub>	40199	41999	hS1 (Load short-circuit alarm setting value for CT1)
00C7 <sub>H</sub>	40200	41200	hS1h (Load short-circuit alarm hysteresis for CT1)
00CC <sub>H</sub>	40205	41205	LbTM
00CD <sub>H</sub>	40206	41206	LbAb
00DC <sub>H</sub>	40221	41221	Svn (Selectable SV numbers)
00DD <sub>H</sub>	40222	41222	PLn1 (Currently selected PID No.)
00DF <sub>H</sub>	40224	41224	SvMX (Selectable SV numbers)
00E0 <sub>H</sub>	40225	41225	PL1M (Currently selected PID No.)
00E6 <sub>H</sub>	40231	41231	Front SV set value
00E7 <sub>H</sub>	40232	41232	P (Proportional band)
00E8 <sub>H</sub>	40233	41233	i (Integration time)
00E9 <sub>H</sub>	40234	41234	d (Derivation time)
00EA <sub>H</sub>	40235	41235	hYS (ON/OFF control hysteresis)
00EB <sub>H</sub>	40236	41236	CoL (Cooling proportional band coefficient)
00EC <sub>H</sub>	40237	41237	db (Dead band)
00ED <sub>H</sub>	40238	41238	bAL (output convergence value)
00EE <sub>H</sub>	40239	41239	Ar (Anti-reset windup)
00EF <sub>H</sub>	40240	41240	rEv (Sets normal/reverse operations)
00F0 <sub>H</sub>	40241	41241	Sv1 (SV set value 1)
00F1 <sub>H</sub>	40242	41242	P1 (Proportional band 1)
00F2 <sub>H</sub>	40243	41243	i1 (Integration time 1)
00F3 <sub>H</sub>	40244	41244	d1 (Derivation time 1)
00F4 <sub>H</sub>	40245	41245	hYS1 (ON/OFF control hysteresis 1)
00F5 <sub>H</sub>	40246	41246	CoL1 (Cooling proportional band 1)
00F6 <sub>H</sub>	40247	41247	db1 (Dead band)
00F7 <sub>H</sub>	40248	41248	bAL1 (output convergence value1)
00F8 <sub>H</sub>	40249	41249	Ar1 (Anti-reset windup 1)
00F9 <sub>H</sub>	40250	41250	rEv1 (Sets normal/reverse operations 1)
00FA <sub>H</sub>	40251	41251	Sv2 (SV set value 2)
00FB <sub>H</sub>	40252	41252	P2 (Proportional band 2)
00FC <sub>H</sub>	40253	41253	i2 (Integration time 2)
00FD <sub>H</sub>	40254	41254	d2 (derivation time 2)
00FE <sub>H</sub>	40255	41255	hYS2 (ON/OFF control hysteresis)
00FF <sub>H</sub>	40256	41256	CoL2 (Cooling proportional band 2)
0100 <sub>H</sub>	40257	41257	db2 (Dead band 2)
0101 <sub>H</sub>	40258	41258	bAL2 (output convergence value 2)
0102 <sub>H</sub>	40259	41259	Ar2 (Anti-reset windup 2)
0103 <sub>H</sub>	40260	41260	rEv2 (Sets normal/reverse operations 2)
0104 <sub>H</sub>	40261	41261	Sv3 (SV set value 3)

Relative address	Resistor Number		Parameter contents
	Internal	Engineering unit	
0105 <sub>H</sub>	40262	41262	P3 (Proportional band 3)
0106 <sub>H</sub>	40263	41263	i3 (Integration time 3)
0107 <sub>H</sub>	40264	41264	d3 (derivation time 3)
0108 <sub>H</sub>	40265	41265	hYS3 (ON/OFF control hysteresis)
0109 <sub>H</sub>	40266	41266	CoL3 (Cooling proportional band 3)
010A <sub>H</sub>	40267	41267	db3 (Dead band 3)
010B <sub>H</sub>	40268	41268	bAL3 (output convergence value 3)
010C <sub>H</sub>	40269	41269	Ar3 (Anti-reset windup 3)
010D <sub>H</sub>	40270	41270	rEv3 (Sets normal/reverse operations 3)
010E <sub>H</sub>	40271	41271	Sv4 (SV set value 4)
010F <sub>H</sub>	40272	41272	P4 (Proportional band 4)
0110 <sub>H</sub>	40273	41273	i4 (Integration time 4)
0111 <sub>H</sub>	40274	41274	d4 (derivation time 4)
0112 <sub>H</sub>	40275	41275	hYS4 (ON/OFF control hysteresis)
0113 <sub>H</sub>	40276	41276	CoL4 (Cooling proportional band 4)
0114 <sub>H</sub>	40277	41277	db4 (Dead band 4)
0115 <sub>H</sub>	40278	41278	bAL4 (output convergence value 4)
0116 <sub>H</sub>	40279	41279	Ar4 (Anti-reset windup 4)
0117 <sub>H</sub>	40280	41280	rEv4 (Sets normal/reverse operations 4)
0118 <sub>H</sub>	40281	41281	Sv5 (SV set value 5)
0119 <sub>H</sub>	40282	41282	P5 (Proportional band 5)
011A <sub>H</sub>	40283	41283	i5 (Integration time 5)
011B <sub>H</sub>	40284	41284	d5 (derivation time 5)
011C <sub>H</sub>	40285	41285	hYS5 (ON/OFF control hysteresis)
011D <sub>H</sub>	40286	41286	CoL5 (Cooling proportional band 5)
011E <sub>H</sub>	40287	41287	db5 (Dead band 5)
011F <sub>H</sub>	40288	41288	bAL5 (output convergence value 5)
0120 <sub>H</sub>	40289	41289	Ar5 (Anti-reset windup 5)
0121 <sub>H</sub>	40290	41290	rEv5 (Sets normal/reverse operations 5)
0122 <sub>H</sub>	40291	41291	Sv6 (SV set value 6)
0123 <sub>H</sub>	40292	41292	P6 (Proportional band 6)
0124 <sub>H</sub>	40293	41293	i6 (Integration time 6)
0125 <sub>H</sub>	40294	41294	d6 (Derivation time 6)
0126 <sub>H</sub>	40295	41295	hYS6 (ON/OFF control hysteresis)
0127 <sub>H</sub>	40296	41296	CoL6 (Cooling proportional band 6)
0128 <sub>H</sub>	40297	41297	db6 (Dead band 6)
0129 <sub>H</sub>	40298	41298	bAL6 (output convergence value 6)
012A <sub>H</sub>	40299	41299	Ar6 (Anti-reset windup 6)
012B <sub>H</sub>	40300	41300	rEv6 (Sets normal/reverse operations 6)
012C <sub>H</sub>	40301	41301	Sv7 (SV set value 7)
012D <sub>H</sub>	40302	41302	P7 (Proportional band 7)
012E <sub>H</sub>	40303	41303	i7 (Integration time 7)
012F <sub>H</sub>	40304	41304	d7 (Derivation time 7)
0130 <sub>H</sub>	40305	41305	hYS7 (ON/OFF control hysteresis)
0131 <sub>H</sub>	40306	41306	CoL7 (Cooling proportional band 7)
0132 <sub>H</sub>	40307	41307	db7 (Dead band 7)

Relative address	Resistor Number		Parameter contents
	Internal	Engineering unit	
0133 <sub>H</sub>	40308	41308	bAL7 (output convergence value 7)
0134 <sub>H</sub>	40309	41309	Ar7 (Anti-reset windup 7)
0135 <sub>H</sub>	40310	41310	rEv7 (Sets normal/reverse operations 7)
0154 <sub>H</sub>	40341	41341	PvT (PV input types)
0155 <sub>H</sub>	40342	41342	Pvb (PV input lower limit)
0156 <sub>H</sub>	40343	41343	PvF (PV input upper limit)
0157 <sub>H</sub>	40344	41344	Pvd (decimal position)
0158 <sub>H</sub>	40345	41345	PvU (Unit display)
015A <sub>H</sub>	40347	41347	PvoF (PV input shift)
015B <sub>H</sub>	40348	41348	SvoF (SV input shift)
015C <sub>H</sub>	40349	41349	SVL (SV limit (lower))
015D <sub>H</sub>	40350	41350	Svh (SV limit (upper))
015E <sub>H</sub>	40351	41351	TF (PV input filter)
015F <sub>H</sub>	40352	41352	AdJ0 (PV display zero adjustment)
0160 <sub>H</sub>	40353	41353	AdJS (PV display Splan adjustment)
0161 <sub>H</sub>	40354	41354	rCJ (Cold junction compensation)
0162 <sub>H</sub>	40355	41355	reM (Switching remote SV operation)
0163 <sub>H</sub>	40356	41356	rEM0 (RSV zero adjustment)
0164 <sub>H</sub>	40357	41357	rEMS (RSV span adjustment)
0165 <sub>H</sub>	40358	41358	rEMr (RSV Input Range)
0166 <sub>H</sub>	40359	41359	rTF (RSV input filter)
0167 <sub>H</sub>	40360	41360	-
017C <sub>H</sub>	40381	41381	C1r (OUT1 range)
017D <sub>H</sub>	40382	41382	C2r (OUT2 range)
017E <sub>H</sub>	40383	41383	TC1 (OUT1 proportion cycle)
017F <sub>H</sub>	40384	41384	TC2 (OUT2 proportion cycle)
0180 <sub>H</sub>	40385	41385	PLC1 (OUT1 lower limit)
0181 <sub>H</sub>	40386	41386	PhC1 (OUT1 upper limit)
0182 <sub>H</sub>	40387	41387	PLC2 (OUT2 lower limit)
0183 <sub>H</sub>	40388	41388	PhC2 (OUT2 upper limit)
0184 <sub>H</sub>	40389	41389	PCUT (Selects the output limiter type)
0185 <sub>H</sub>	40390	41390	FLo1
0186 <sub>H</sub>	40391	41391	FLo2
0187 <sub>H</sub>	40392	41392	SFo1
0189 <sub>H</sub>	40394	41394	SFTM (Soft start set time)
018D <sub>H</sub>	40398	41398	Sbo1
018E <sub>H</sub>	40399	41399	Sbo2
018F <sub>H</sub>	40400	41400	SbMd (Standby mode settings)
0190 <sub>H</sub>	40401	41401	AoT (AO output type)
0191 <sub>H</sub>	40402	41402	AoL (AO lower limit scaling)
0192 <sub>H</sub>	40403	41403	AoH (AO upper limit scaling)
01A4 <sub>H</sub>	40421	41421	CTrL (control method)
01A5 <sub>H</sub>	40422	41422	onoF (ON/OFF control hysteresis)
01A6 <sub>H</sub>	40423	41423	SLFb (Pv stable width during self-tuning)
01A7 <sub>H</sub>	40424	41424	PrCS (Control target)
01A8 <sub>H</sub>	40425	41425	PGAP (PFB Dead Band)

Relative address	Resistor Number		Parameter contents
	Internal	Engineering unit	
01A9H	40426	41426	TrvL (Valve stroke time)
01ABH	40428	41428	CAL (PFB input adjustment command)
01ACH	40429	41429	rMP (Ramp SV - effect/no effect)
01ADH	40430	41430	rMPL (Ramp SV - decline)
01AEH	40431	41431	rMPH (Ramp SV - incline)
01AFH	40432	41432	rMPU (Ramp SV slope time unit)
01B0H	40433	41433	SvT (Ramp SV - SV display mode selection)
01B1H	40434	41434	STMd (Startup mode)
01C2H	40451	41451	dP01 (Parameter display mask)
01C3H	40452	41452	dP02 (Parameter display mask)
01C4H	40453	41453	dP03 (Parameter display mask)
01C5H	40454	41454	dP04 (Parameter display mask)
01C6H	40455	41455	dP05 (Parameter display mask)
01C7H	40456	41456	dP06 (Parameter display mask)
01C8H	40457	41457	dP07 (Parameter display mask)
01C9H	40458	41458	dP08 (Parameter display mask)
01CAH	40459	41459	dP09 (Parameter display mask)
01CBH	40460	41460	dP10 (Parameter display mask)
01CCH	40461	41461	dP11 (Parameter display mask)
01CDH	40462	41462	dP12 (Parameter display mask)
01CEH	40463	41463	dP13 (Parameter display mask)
01CFH	40464	41464	dP14 (Parameter display mask)
01D0H	40465	41465	dP15 (Parameter display mask)
01D1H	40466	41466	dP16 (Parameter display mask)
01D2H	40467	41467	dP17 (Parameter display mask)
01D3H	40468	41468	dP18 (Parameter display mask)
01D4H	40469	41469	dP19 (Parameter display mask)
01D5H	40470	41470	dP20 (Parameter display mask)
01D6H	40471	41471	dP21 (Parameter display mask)
01D7H	40472	41472	dP22 (Parameter display mask)
01D8H	40473	41473	dP23 (Parameter display mask)
01D9H	40474	41474	dP24 (Parameter display mask)
01DAH	40475	41475	dP25 (Parameter display mask)
01DBH	40476	41476	dP26 (Parameter display mask)
01DCH	40477	41477	dP27 (Parameter display mask)
01DDH	40478	41478	dP28 (Parameter display mask)
01DEH	40479	41479	dP29 (Parameter display mask)
01DFH	40480	41480	dP30 (Parameter display mask)
0208H	40521	41521	PASS (Password input)
0209H	40522	41522	PAS1 (Password 1 setup)
020AH	40523	41523	PAS2 (Password 2 setup)
020BH	40524	41524	PAS3 (Password 3 setup)
0212H	40531	41531	ToUT (Display timeout setting)
0214H	40533	41533	r-Fk (During remote selection setting, SV display blinking settings)

Relative address	Resistor Number		Parameter contents
	Internal	Engineering unit	
0215H	40534	41534	SoFk (During soft start selection, SV display blinking settings)
0216H	40535	41535	ALMF (During ALM, DO lamp blink settings)
0217H	40536	41536	rST (Reset main unit)
0218H	40537	41537	bCon (Select controll at burnout)
0219H	40538	41538	PTnT (Ramp/soak pattern type)
021DH	40542	41542	L-C2 (LED lamp allocation (C2))
0230H	40561	41561	PTn (Ramp/soak progress)
0231H	40562	41562	TiMU (Ramp/soak time units)
0232H	40563	41563	Mod (Ramp/soak mode)
0233H	40564	41564	PTnM (Sets the max pattern selection)
0234H	40565	41565	PMin (Sets the min pattern selection)
023AH	40571	41571	Gsok (Guaranty soak ON/OFF)
023BH	40572	41572	GS-L (Guaranty soak (lower limit))
023CH	40573	41573	GS-h (Guaranty soak (upper limit))
023DH	40574	41574	PvST (PV start)
023EH	40575	41575	ConT (Restore mode)
0244H	40581	41581	Sv-1 (Ramp/soak 1 seg/SV set value)
0245H	40582	41582	TM1r (Ramp/soak 1 seg ramp time)
0246H	40583	41583	TM1S (Ramp/soak 1 seg soak time)
0247H	40584	41584	Sv-2 (Ramp/soak 2 seg/SV set value)
0248H	40585	41585	TM2r (Ramp/soak 2 seg ramp time)
0249H	40586	41586	TM2S (Ramp/soak 2 seg soak time)
024AH	40587	41587	Sv-3 (Ramp/soak 3 seg/SV set value)
024BH	40588	41588	TM3r (Ramp/soak 3 seg ramp time)
024CH	40589	41589	TM3S (Ramp/soak 3 seg soak time)
024DH	40590	41590	Sv-4 (Ramp/soak 4 seg/SV set value)
024EH	40591	41591	TM4r (Ramp/soak 4 seg ramp time)
024FH	40592	41592	TM4S (Ramp/soak 4 seg soak time)
0250H	40593	41593	Sv-5 (Ramp/soak 5 seg/SV set value)
0251H	40594	41594	TM5r (Ramp/soak 5 seg ramp time)
0252H	40595	41595	TM5S (Ramp/soak 5 seg soak time)
0253H	40596	41596	Sv-6 (Ramp/soak 6 seg/SV set value)
0254H	40597	41597	TM6r (Ramp/soak 6 seg ramp time)
0255H	40598	41598	TM6S (Ramp/soak 6 seg soak time)
0256H	40599	41599	Sv-7 (Ramp/soak 7 seg/SV set value)
0257H	40600	41600	TM7r (Ramp/soak 7 seg ramp time)
0258H	40601	41601	TM7S (Ramp/soak 7 seg soak time)
0259H	40602	41602	Sv-8 (Ramp/soak 8 seg/SV set value)
025AH	40603	41603	TM8r (Ramp/soak 8 seg ramp time)
025BH	40604	41604	TM8S (Ramp/soak 8 seg soak time)
025CH	40605	41605	Sv-9 (Ramp/soak 9 seg/SV set value)
025DH	40606	41606	TM9r (Ramp/soak 9 seg ramp time)
025EH	40607	41607	TM9S (Ramp/soak 9 seg soak time)
025FH	40608	41608	Sv10 (Ramp/soak 10 seg/SV set value)
0260H	40609	41609	T10r (Ramp/soak 10 seg ramp time)

Relative address	Resistor Number		Parameter contents
	Internal	Engineering unit	
0261 <sub>H</sub>	40610	41610	T10S (Ramp/soak 10 seg soak time)
0262 <sub>H</sub>	40611	41611	Sv11 (Ramp/soak 11 seg/SV set value)
0263 <sub>H</sub>	40612	41612	T11r (Ramp/soak 11 seg ramp time)
0264 <sub>H</sub>	40613	41613	T11S (Ramp/soak 11 seg soak time)
0265 <sub>H</sub>	40614	41614	Sv12 (Ramp/soak 12 seg/SV set value)
0266 <sub>H</sub>	40615	41615	T12r (Ramp/soak 12 seg ramp time)
0267 <sub>H</sub>	40616	41616	T12S (Ramp/soak 12 seg soak time)
0268 <sub>H</sub>	40617	41617	Sv13 (Ramp/soak 13 seg/SV set value)
0269 <sub>H</sub>	40618	41618	T13r (Ramp/soak 13 seg ramp time)
026A <sub>H</sub>	40619	41619	T13S (Ramp/soak 13 seg soak time)
026B <sub>H</sub>	40620	41620	Sv14 (Ramp/soak 14 seg/SV set value)
026C <sub>H</sub>	40621	41621	T14r (Ramp/soak 14 seg ramp time)
026D <sub>H</sub>	40622	41622	T14S (Ramp/soak 14 seg soak time)
026E <sub>H</sub>	40623	41623	Sv15 (Ramp/soak 15 seg/SV set value)
026F <sub>H</sub>	40624	41624	T15r (Ramp/soak 15 seg ramp time)
0270 <sub>H</sub>	40625	41625	T15S (Ramp/soak 15 seg soak time)
0271 <sub>H</sub>	40626	41626	Sv16 (Ramp/soak 16 seg/SV set value)
0272 <sub>H</sub>	40627	41627	T16r (Ramp/soak 16 seg ramp time)
0273 <sub>H</sub>	40628	41628	T16S (Ramp/soak 16 seg soak time)

### Word Data (read only): function code [04 (H)]

#### Monitor (Ch5)

Parameter display	Parameter name	Contents	Relative address	Resistor Number		Type	Read data	Dependent on range
				Internal	Engineering unit			
"STAT"	STAT	Ramp/soak progress	0028 <sub>H</sub>	30041	31041	Word	oFF (ramp/soak is stopped) 1rP (Step 1 Ramp) 1Sk (soak is in step 1) ⋮ 16rP (Step 16 Ramp) 16Sk (soak is in step 16) End (ramp/soak is finished)	
"Mv1"	Mv1	Control output 1	0029 <sub>H</sub>	30042	31042	Word	-300 to 10300 (-3.00 to 103.00%FS)	
"Mv2"	Mv2	Control output 2	002A <sub>H</sub>	30043	31043	Word	-300 to 10300 (-3.00 to 103.00%FS)	
"PFb"	PFb	PFB Input Value Display	002B <sub>H</sub>	30044	31044	Word	-300 to 10300 (-3.00 to 103.00%FS)	
"rSv"	rSv	RSV input value display	002C <sub>H</sub>	30045	31045	Word	-500 to 10500 (-5.00 to 105.00%FS)	
"CT1"	CT1	Heater current	002D <sub>H</sub>	30046	31046	Word	0 to 500 (0, 0.4 to 50.0A)	
"LC1"	LC1	Leak current value	002F <sub>H</sub>	30048	31048	Word	0 to 500 (0, 0.4 to 50.0A)	
"TM1"	TM1	Remaining time on timer 1	0031 <sub>H</sub>	30050	31050	Word	0 sec to 9999 sec / 0 min to 9999 min	
"TM2"	TM2	Remaining time on timer 2	0032 <sub>H</sub>	30051	31051	Word	0 sec to 9999 sec / 0 min to 9999 min	
"TM3"	TM3	Remaining time on timer 3	0033 <sub>H</sub>	30052	31052	Word	0 sec to 9999 sec / 0 min to 9999 min	
"TM4"	TM4	Remaining time on timer 4	0034 <sub>H</sub>	30053	31053	Word	0 sec to 9999 sec / 0 min to 9999 min	
"TM5"	TM5	Remaining time on timer 5	0035 <sub>H</sub>	30054	31054	Word	0 sec to 9999 sec / 0 min to 9999 min	
"FALT"	FALT	Error source display	0036 <sub>H</sub>	30055	31055	Word	0000 to 1100	
"PLno"	PLno	Current palette	0038 <sub>H</sub>	30057	31057	Word	0~7	
"PTno"	PTno	Current pattern	0039 <sub>H</sub>	30058	31058	Word	0~6	

Other

Parameter display	Parameter name	Contents	Relative address	Resistor Number		Type	Read data	Dependent on range
				Internal	Engineering unit			
Display PV value	Pv (measurement)		0000H	30001	31001	Word	0 to 10000 (0.00 to 100.00%FS)	○
Display SV Value	Sv (Currently used set value)		0001H	30002	31002	Word	0 to 10000 (0.00 to 100.00%FS)	○
-	DV (Currently used deviation)		0002H	30003	31003	Word	-10000 to 10000 (-100.00 to 100.00%FS)	○
"r1"	Mv1	Output 1	0003H	30004	31004	Word	-300 to 10300 (-3.00 to 103.00%FS)	
"r2"	Mv2	Output 2	0004H	30005	31005	Word	-300 to 10300 (-3.00 to 103.00%FS)	
"STNo"	STNo	STATION No.	0005H	30006	31006	Word	0 to 255	
-	DO STATUS		0006H	30007	31007	Word	See the table [DO STATUS] below.	
"FALT"	FALT	FALT STATUS	0007H	30008	31008	Word	0000 to 1100	
"STAT"	STAT	Ramp/Soak progress	0008H	30009	31009	Word	0: oFF (ramp/soak is stopped) 1: 1-rP (Step 1 Ramp) 2: 1-Sk (Step 1 Soak) ⋮ 31: 16-rP (Step 16 Ramp) 32: 16-Sk (Step 16 Soak) 33: End (ramp/soak is finished)	
"CT1"	CT1	Heater current	0009H	30010	31010	Word	0 to 500 (0.0 to 50.0A)	
"TM1"	TM1	Remaining time on timer 1	000AH	30011	31011	Word	0 sec to 9999 sec / 0 min to 9999 min	
"TM2"	TM2	Remaining time on timer 2	000BH	30012	31012	Word	0 sec to 9999 sec / 0 min to 9999 min	
"TM3"	TM3	Remaining time on timer 3	000CH	30013	31013	Word	0 sec to 9999 sec / 0 min to 9999 min	
"DI"	DI		000EH	30015	31015	Word		
-	rCJ (Cold junction compensation)	Terminal temperature	000FH	30016	31016	Word	-10000 to 10000 (-100.00 to 100.00%FS) -1999 to 9999 (-199.9 to 999.9°C)	
"rSV"	rSV	RSV input value display	0024H	30037	31037	Word		
-	DI STATUS		003CH	30061	31061	Word		
-	STAT		003DH	30062	31062	Word		

[DO STATUS]

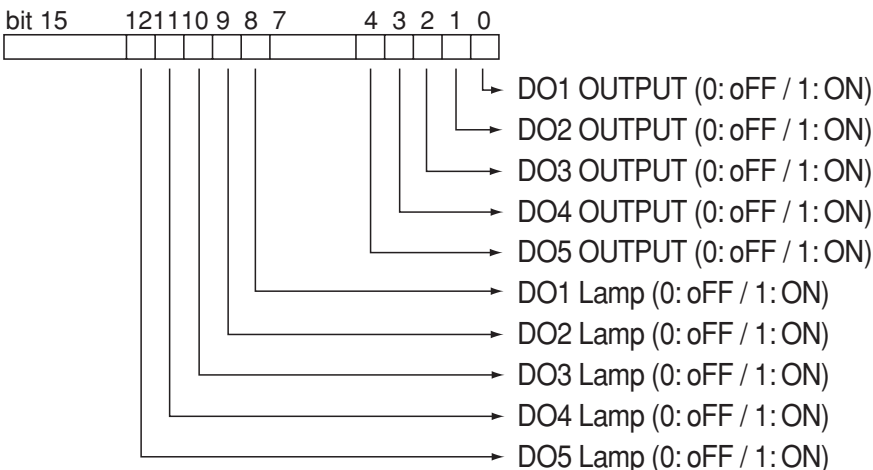

## Resistor Number Order Read Parameter List

Relative address	Resistor Number		Type	Memory contents
	Internal	Engineering unit		
0000 <sub>H</sub>	30001	31001	Word	PV (measurement)
0001 <sub>H</sub>	30002	31002	Word	SV (Currently used set value)
0002 <sub>H</sub>	30003	31003	Word	DV (Currently used deviation)
0003 <sub>H</sub>	30004	31004	Word	Mv1 (output 1)
0004 <sub>H</sub>	30005	31005	Word	Mv2 (output 2)
0005 <sub>H</sub>	30006	31006	Word	STATION No.
0006 <sub>H</sub>	30007	31007	Word	ALM STATUS
0007 <sub>H</sub>	30008	31008	Word	FALT STATUS
0008 <sub>H</sub>	30009	31009	Word	STAT (Ramp/soak progress)
0009 <sub>H</sub>	30010	31010	Word	HB INPUT
000A <sub>H</sub>	30011	31011	Word	TM1 (Remaining time on timer 1)
000B <sub>H</sub>	30012	31012	Word	TM2 (Remaining time on timer 2)
000C <sub>H</sub>	30013	31013	Word	TM3 (Remaining time on timer 3)
000E <sub>H</sub>	30015	31015	Word	DI STATUS
000F <sub>H</sub>	30016	31016	Word	rCJ (Cold junction compensation)
0024 <sub>H</sub>	30037	31037	Word	rEM (Remote switching status)
0028 <sub>H</sub>	30041	31041	Word	STAT (Ramp/soak progress)
0029 <sub>H</sub>	30042	31042	Word	Mv1 (output 1)
002A <sub>H</sub>	30043	31043	Word	Mv2 (output 2)
002B <sub>H</sub>	30044	31044	Word	PFb input value display
002C <sub>H</sub>	30045	31045	Word	rSv input value display
002D <sub>H</sub>	30046	31046	Word	CT1 (Heater current)
002F <sub>H</sub>	30048	31048	Word	LC1 (Leak current value)
0031 <sub>H</sub>	30050	31050	Word	TM1 (Remaining time on timer 1)
0032 <sub>H</sub>	30051	31051	Word	TM2 (Remaining time on timer 2)
0033 <sub>H</sub>	30052	31052	Word	TM3 (Remaining time on timer 3)
0034 <sub>H</sub>	30053	31053	Word	TM4 (Remaining time on timer 4)
0035 <sub>H</sub>	30054	31054	Word	TM5 (Remaining time on timer 5)
0036 <sub>H</sub>	30055	31055	Word	FALT STATUS
0038 <sub>H</sub>	30057	31057	Word	PLno (Current palette No.)
0039 <sub>H</sub>	30058	31058	Word	PTno (Current pattern No.)
003B <sub>H</sub>	30060	31060	Word	ALM STATUS
003C <sub>H</sub>	30061	31061	Word	DI STATUS
003D <sub>H</sub>	30062	31062	Word	STAT

---

## MEMO