

# KOSMOS SERIE

CODE: 30727031 EDITION: 01-08-2011



INSTRUCTIONS MANUAL  
COUNTER - TOTALIZER  
TACHOMETER - TOTALIZER  
FREQUENCY METER  
CHRONOMETER  
PART 2 / 2



**MODEL ALPHA-D**  
MODBUS-RTU PROTOCOL COMPATIBLE



# ANNEXES

---

## Index

---

SECTION	Page
<b>ANEXO A. SETPOINTS</b> .....	58
Programming Diagram .....	58
A.1. Counter / Chronometer Configuration .....	59
A.1.1. Programming the Setpoint Values.....	59
A.1.2. Programming the Operating Mode.....	60-61-62
A.1.3. Programming the Timed Output .....	62
A.2. Frequency meter / Tachometer Configuration.....	63
A.2.1. Programming the Setpoint Values.....	63
A.2.2. Programming the Operating Mode.....	64-65-66
A.2.3. Programming the Delay/Hysteresis .....	66
<b>ANNEXE B. SERIAL OUTPUTS RS232C AND RS485</b> .....	67
B.1. List of Commands .....	67 a 69
B.2. Address of the Variables in the Memory .....	70 a 79

# ANNEXE A. SETPOINTS

## Program Routines

The **SEtP** programming module is identical whatever may be the meter's configuration, although some options have different applications. This annexe is divided in two parts; A1 for counter/chronometer and A2 for frequency/tachometer.

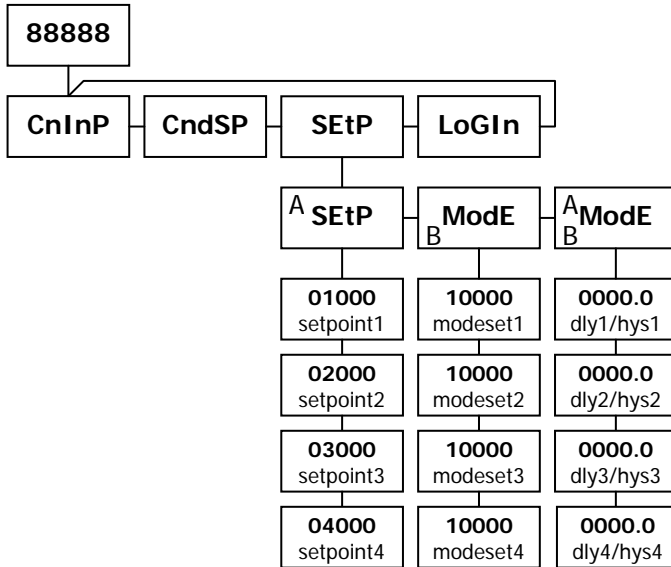

The diagram represents the module '**SetP**' that includes 3 menus:

**3A SetP:** Setpoint numerical values

**3B ModE:** Setpoint operating modes

**3AB ModE:** Pulse width, delay or hysteresis numerical values.

(In the diagram, there are four steps per each menu that correspond to each of the four setpoints. If the meter has only two setpoints -2RE option-, the two last steps of each menu are omitted)

### DIRECT ACCESS TO PROGRAM SETPOINT VALUES

The instrument has a direct access from the run mode to program the values of the setpoints. The access is obtained pressing key ENTER to enter -Pro- and key LIMIT to call the setpoints list. The number of the setpoint being programmed is indicated by the corresponding LED on the right of the display. The changes made in this routine are transferred automatically to the menu A SetP and stored in the memory.

# A.1. Counter / Chronometer Configuration

## A.1.1. Setpoint Values Programming

**IMPORTANT:** The setpoint values are programmed according to the variable to which they are referred, taking from this the number of digits, the position of the decimal and the position of the sign, thus is **necessary to program first, before the setpoint value, the digits that determine the control mode in menu 3B Mode**

### COUNTER

When the setpoint is referred the **PROCESS** variable, that is to the partial count, the sign is programmed in the auxiliary digit and the value in the five digits of the display. The decimal point is located in the position programmed for the PROCESS variable

Positive 

Negative 

When the setpoint is referred to the **BATCH** variable, that is to the batch counter, it has no sign, since it is always positive, and no decimal point.

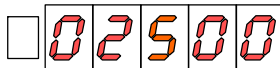

When the setpoint is referred the the **TOTAL** variable, that is to the totalizer, the value is programmed in two steps; First the high part, of three digits, where first one can be a minus sign. Later the low part, of five digits with the decimal point in the position of the totalizer.



### CHRONOMETER

In the chronometer configuration, the setpoint is programmed referred to the only variable it has, **PROCESS**, without sign and with the decimal point located according to the selected scale

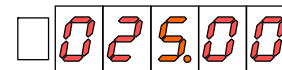

## A.1.2. Programming the Control Mode

The menu "**3B ModE**" allows programming all parameters relating the setpoints control mode.

The control mode is defined by 5 digits, each one representing a particular function for the setpoint.

The digits are numbered 1 to 5, from left to right.

### DIGIT 1 ON-OFF SELECTION

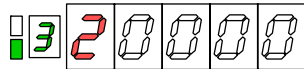

#### 0=disabled

No operation

#### 1=pulse

The output activates when the setpoint is reached and deactivates after a programmable time out value between 0000.1 and 9999.9 s

#### 2=latch

The output is active when the display reaches the setpoint and deactivates when display falls below the setpoint level.

#### 3=rscm

The output activation and deactivation is controlled by a command received via the serial port (see commands on page 68)

### DIGIT 2 HI-LO SELECTION

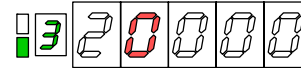

#### 0=HI

The output activates when the setpoint is reached

#### 1=LO

The output deactivates when the setpoint is reached

### SUMMARY OF MODES ON-OFF/ HI-LO

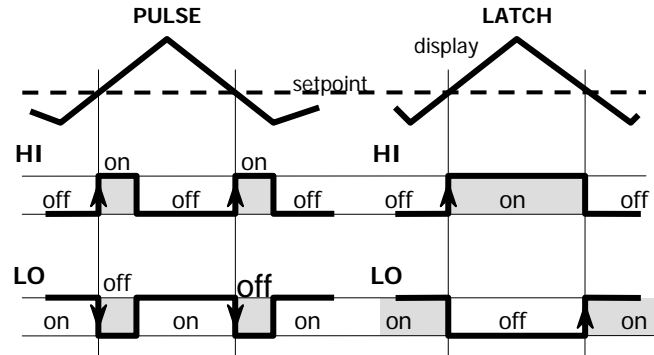

(▲ : alarm activation edge where the reset, stop and clear functions are active)

## DIGIT 3 FUNCTION

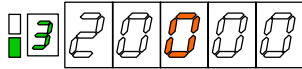

**0=no**  
No function

**1=reset**  
When the output activates the variable compared with the setpoint is set to zero or the offset value.  
(When this function is selected, the digit 1 cannot be set for latched operation -option 2-)

**2=stop**  
The output activation disables pulse count on both inputs and holds all counter displays.  
If the setpoint is programmed for timed output (pulse), after the time delay the meter continues the normal operation.  
If the setpoint is programmed for latched mode, the meter restarts when the user resets the variable referred by the setpoint.

**3=clear**  
When activated, the output of the preceding setpoint is reset to the OFF state.  
(The setpoint preceding the number 1 is number 4)

## DIGIT 4 REFERENCE VARIABLE

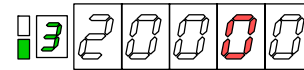

**0=process**  
Setpoint referred to the process variable, that is to the partial count in counter mode or to the chronometer time display

**1=batch**  
Setpoint referred to the batch variable. This option cannot be set if the batch counter is disabled or in chronometer mode

**2=total**  
Setpoint referred to the total variable. This option cannot be set if the totalizer counter is disabled or in chronometer mode

**3=batch indication**  
Setpoint used for batch indication. The output is active every time a batch event is performed, that is each time the batch variable is incremented in one unit. This option cannot be set if the batch counter is disabled or in chronometer mode

## DIGIT 5 ALARM INDICATION

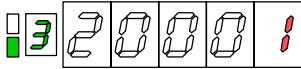

### 0=LED

The alarm activation is acknowledged in the display by the right side LED indicator corresponding to the setpoint number associated to such alarm

### 1=LED+BLINK

The alarm activation illuminates the corresponding LED indicator and also flashes all the digits of the display. This option is suitable for use in installations where the LED indicator is insufficiently readable due to room brightness or distance to the operator's eye.

## A.1.3. Time Delay for Timed Outputs

---

When the setpoint is programmed for pulse output (digit 1, option 1 in previous section), the "**3AB Mode**" menu allows programming the amount of time, in seconds, that the output will be active.

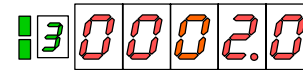

The decimal point location denotes that the time value can be programmed with a resolution of tenths (figure shows a 2s programming).

If this parameter is set to zero, the pulse duration is not guaranteed. It may vary from a few milliseconds to approximately 20ms.

## A.2. Frequency meter / Tachometer Configuration

### A.2.1. Programming the Setpoint Values

**IMPORTANT:** The setpoint values are programmed according to the variable to which they refer, taking from this the number of digits, the position of the decimal and the position of the sign, thus **is necessary to program first, before the setpoint value, the digits that determine the control mode in menu 3B ModE.**

#### PROCESS VARIABLE WITHOUT SIGN.

For applications where the variable is read without polarity indication, the setpoint value has not "sign" indication and is programmed in the five digits of the display with the decimal point according to the process variable.

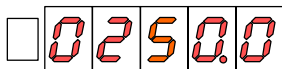

#### PROCESS VARIABLE WITH SIGN

For applications involving sensing of polarity or direction of rotation, the LED's A and B are used to set the sign of the setpoint.

If the setpoint value is programmed with the **LED A**, the output will activate each time the display reaches this value, **both in positive and in negative direction**

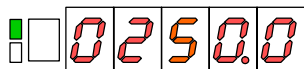

If the setpoint value is programmed with the **LED B**, the output will activate when the display reaches this value **exclusively in the negative direction.**



#### INDICATOR OF NEGATIVE DIRECTION

The setpoints configured for negative direction indication (according to the settings in the control mode digits in menu 3B ModE, see next section digit 4) do not need to be programmed for a specific numerical value.

In this mode, the setpoint is used to control polarity or direction of rotation by changing the state of the control output whenever the polarity of the variable being measured is changed.

#### TOTAL VARIABLE

A setpoint referred to the totalizer is programmed in two steps; first the high order 3 digits, where the first one can be a minus sign. Then the low order 5 digits with the decimal point in the position of the totalizer display.

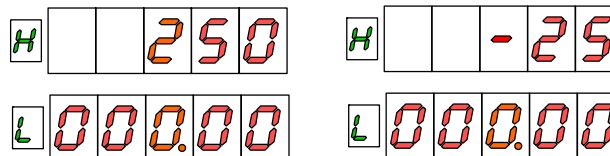

## A.2.2. Programming the Operating Mode

The menu "**3B ModE**" allows programming all parameters relating the setpoints operating mode.

The control mode is defined by 5 digits, each one representing a particular function of the setpoint.

The digits are numbered 1 to 5, from left to right

### DIGIT 1 ON-OFF SELECTION

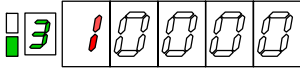

#### 0=disabled

No operation

#### 1=normal

The output activates when the display reaches the setpoint and deactivates when it falls below the setpoint

#### 2=latch

The output activates and latches when the display reaches the setpoint and remains active although the alarm condition disappears. A 'RESET LATCH' signal at rear connector (see page 45, function n°25) unlocks the latched outputs

#### 3=rscm

The output activation and deactivation is controlled by a command received via the serial port (see commands on page 68)

### DIGIT 2 HI-LO SELECTION

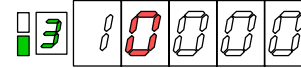

#### 0=HI

The output activates when the setpoint is reached

#### 1=LO

The output deactivates when the setpoint is reached

### DIGIT 3 DELAY-HYSTERESIS

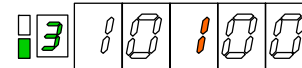

#### 0=delay

The output activation and deactivation occurs after a programmable time delay from the setpoint is reached

#### 1=hysteresis-1

The output activates on the setpoint and deactivates a number of display counts (hysteresis value) below the setpoint

#### 2=hysteresis-2

The output activates a number of display counts (hysteresis value) below the setpoint and deactivates the same number of counts above the setpoint

## SUMMARY OF MODES HI-LO / DELAY-HYSTERESIS

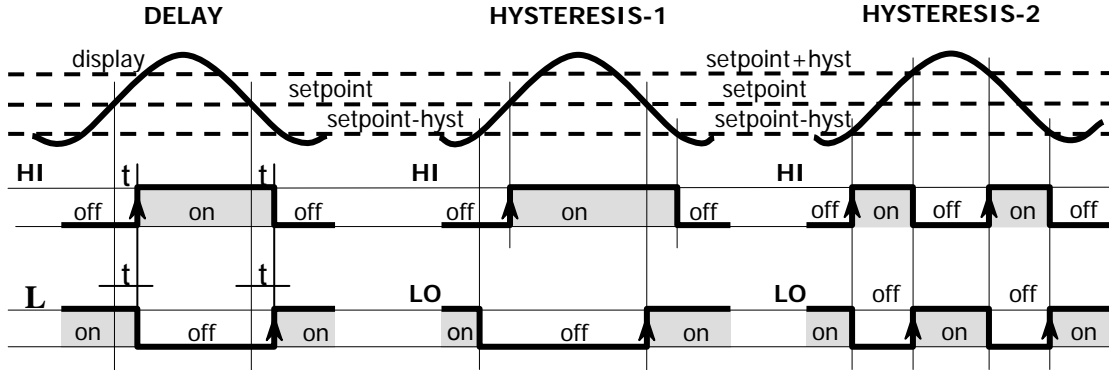

(▲: Output activation edge where the latch setpoints are latched)

### DIGIT 4 REFERENCE VARIABLE

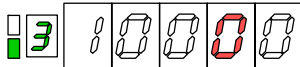

#### 0=process

Setpoint referred to the process variable, that is, to the instantaneous value for frequency, rate, flow, etc..

#### 1=track

Used as a pre-alarm or security alarm of the preceding setpoint. The value of a tracking setpoint is the amount of display counts with respect to the preceding setpoint, that the pre-alarm activates before main alarm condition is set.

#### 2=total

Setpoint referred to the totalizer display (see configuration of the other digits in pages 60, 61 and 62)

#### 3=peak

Setpoint referred to the peak variable

#### 4=valley

Setpoint referred to the valley variable

#### 5=sign

Setpoint referred to the polarity of the process variable. The output activates when the polarity or direction or rotation of the variable is negative

## DIGIT 5 ALARM INDICATION

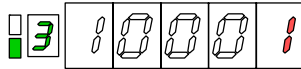

### 0=LED

The alarm activation is acknowledged in the display by the right side LED indicator corresponding to the setpoint number associated to such alarm

### 1=LED+BLINK

The alarm activation illuminates the corresponding LED indicator and also flashes all the digits of the display. This option is suitable for use in installations where the LED indicator is insufficiently readable due to room brightness or distance to the operator's eye

## A.2.3. Delay or Hysteresis Values

---

"3AB Mode" menu allows programming the time delay in seconds, or hysteresis value in counts of display that the output will be active.

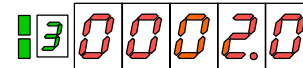

When programming time delay, the decimal point is located to the fourth digit so the value can be set with a resolution of tenths (figure shows a 2s programming).

When programming hysteresis value, the decimal point appears in the same position as in the setpoint reference variable.

## ANNEXE B. SERIAL OUTPUTS RS232C or RS485

---

### B.1. List of Commands

---

#### DATA REQUEST

ASCII	ISO	Information issued
I	OI	State of the logic inputs
P	OP	Peak reading
V	OV	Valley reading
T	OT	Offset value
D	OD	Present display Value
Z	OZ	Totalizer value
X	OX	Batch number
C	OC	Type of input (configuration)
L1	L1	Setpoint1 value
L2	L2	Setpoint2 value
L3	L3	Setpoint3 value
L4	L4	Setpoint4 value

#### MODIFICATION OF DATA

ASCII	ISO	Parameter
M1	M1	Change setpoint1 in memory
M2	M2	Change setpoint2 in memory
M3	M3	Change setpoint3 in memory
M4	M4	Change setpoint4 in memory
S1	S1	Change setpoint1 without saving
S2	S2	Change setpoint2 without saving
S3	S3	Change setpoint3 without saving
S4	S4	Change setpoint4 without saving

**COMMAND**

ASCII	ISO	MODBUS	Command
n	0n	n	Reset latched setpoint outputs
p	0p	p	Reset peak
v	0v	v	Reset valley
r	0r	r	Reset offset
t	0t	t	Take display value as offset
d	0d	d	Reset process counter
z	0z	z	Reset totalizer counter
x	0x	x	Reset batch counter
a1	a1	a1	Activate setpoint1
a2	a2	a2	Activate setpoint2
a3	a3	a3	Activate setpoint3
a4	a4	a4	Activate setpoint4
d1	d1	d1	Desactivate setpoint1
d2	d2	d2	Desactivate setpoint2
d3	d3	d3	Desactivate setpoint3
d4	d4	d4	Desactivate setpoint4

## B.2. Address of the Variables in the Memory

---

### PROGRAMMING DATA (READ/WRITE)

ISO	MODBUS	Variable	Meaning	
0	0	SETPOINT 1	Sign	
1			Digit 6	
2	1		Digit 5	
3			Digit 4	
4	2		Digit 3	
5			Digit 2	
6	3		Digit 1	
7			Digit 0	
8	4		SETPOINT 2	Sign
9				Digit 6
10	5	Digit 5		
11		Digit 4		
12	6	Digit 3		
13		Digit 2		
14	7	Digit 1		
15		Digit 0		
16	8	SETPOINT 3	Sign	
17			Digit 6	
18	9		Digit 5	
19			Digit 4	
20	10		Digit 3	
21			Digit 2	
22	11		Digit 1	
23			Digit 0	

24	12	SETPOINT 4	Sign
25			Digit 6
26	13		Digit 5
27			Digit 4
28	14		Digit 3
29			Digit 2
30	15		Digit 1
31		Digit 0	
32	16	MODE SETPOINT 1	COUNT: 0=off, 1=pulse, 2=latch, 3=rscom FREQ: 0=off, 1=on, 2=latch, 3=rscom
33			0=hi, 1=lo
34	17		COUNT: 0=no, 1=reset, 2=stop, 3=clear FREQ: 0= delay, 1=hysteresis-1, 2=hysteresis-2
35		COUNT: 0=process, 1=batch, 2=total, 3=lotes FREQ: 0= process, 1=track, 2=total, 3=peak, 4=valley, 5=sign	
36	18	MODE SETPOINT 2	0=LED, 1=LED+blink
37			COUNT: 0=off, 1=pulse, 2=latch, 3=rscom FREQ: 0=off, 1=on, 2=latch, 3=rscom
38	19		0=hi, 1=lo
39			COUNT: 0=no, 1=reset, 2=stop, 3=clear FREQ: 0= delay, 1=hysteresis-1, 2=hysteresis-2
40	20	COUNT: 0=process, 1=batch, 2=total, 3=lotes FREQ: 0= process, 1=track, 2=total, 3=peak, 4=valley, 5=sign	
41		0=LED, 1=LED+blink	

42	21	MODE SETPOINT 3	COUNT: 0=off, 1=pulse, 2=latch, 3=rscom FREQ: 0=off, 1=on, 2=latch, 3=rscom
43			0=hi, 1=lo
44	22		COUNT: 0=no, 1=reset, 2=stop, 3=clear FREQ: 0= delay, 1=hysteresis-1, 2=hysteresis-2
45			COUNT: 0=proceso, 1=batch, 2=total, 3=lotes FREQ: 0= process, 1=track, 2=total, 3=peak, 4=valley, 5=signo
46	23		0=LED, 1=LED+blink
47		MODE SETPOINT 4	COUNT: 0=off, 1=pulse, 2=latch, 3=rscom FREQ: 0=off, 1=on, 2=latch, 3=rscom
48	24	MODE SETPOINT 4	0=hi, 1=lo
49			COUNT: 0=no, 1=reset, 2=stop, 3=clear FREQ: 0= delay, 1=hysteresis-1, 2=hysteresis-2
50	25		COUNT: 0=proceso, 1=batch, 2=total, 3=lotes FREQ: 0= process, 1=track, 2=total, 3=peak, 4=valley, 5=sign
51			0=LED, 1=LED+blink
52	26		DELAY / HYSTERESIS SETPOINT 1
53		Digit 3	
54	27	Digit 2	
55		Digit 1	
56	28	Digit 0	
57	29	DELAY / HYSTERESIS SETPOINT 2	Digit 4
58			Digit 3
59			Digit 2
60	30		Digit 1
61			Digit 0

62	31	DELAY / HYSTERESIS SETPOINT 3	Digit 4
63			Digit 3
64	32		Digit 2
65			Digit 1
66	33		Digit 0
67		DELAY / HYSTERESIS SETPOINT 4	Digit 4
68	34		Digit 3
69			Digit 2
70	35		Digit 1
71			Digit 0
72	36	ANALOG OUTPUT LO	Sign
73			Digit 4
74	37		Digit 3
75			Digit 2
76	38		Digit 1
77			Digit 0
78	39		ANALOG OUTPUT HI
79		Digit 4	
80	40	Digit 3	
81		Digit 2	
82	41	Digit 1	
83		Digit 0	
84	42	ANALOG OUTPUT TYPE	
85		INPUT CONFIGURATION	0=counter, 1=chronometer, 2=frequency meter, 3=tachometer
86	43	COUNTER DIRECTION	0=up, 1=down, 2=up/down
87		BIDIRECTIONAL MODE	0=indep, 1=direc, 2=phase

88	44	CHRONO MODE	0=A↑ start A↓ stop (In-A), 1=A↑ start B↑ stop (In-AB), 2=A↑ start A↑ stop (In-AA)
89		CHRONO DIRECTION	0=up, 1=down
90	45	TACH MODE	0=rpm, 1=rate
91		RATE DIRECTION	0=direct, 1=inverse
92	46	CHRONO UNITS	0=9999.9h (H.H), 1=999h59min (H.MM), 2=999min59s (M.SS), 3=9999.9s (0.1-S), 4=999.99s (0.01-S)
93		DISPLAY DEC.POINT	0=88888, 1=8888.8, 2=888.88, 3=88.888, 4=8.8888
94	47	PROC FACTOR DP	0=88888, 1=8888.8, 2=888.88, 3=88.888, 4=8.8888, 5=0.88888
95		PROCESS FACTOR	Digit 4
96	Digit 3		
97	Digit 2		
98	Digit 1		
99	Digit 0		
100	50	TOTAL FACTOR DP	0=88888, 1=8888.8, 2=888.88, 3=88.888, 4=8.8888, 5=0.88888
101		TOTAL FACTOR	Digit 4
102	Digit 3		
103	Digit 2		
104	Digit 1		
105	Digit 0		
106	53	TOTAL DEC POINT	0=88888, 1=8888.8, 2=888.88, 3=88.888, 4=8.8888
107		TOTALIZER	0=no, 1=yes

108	54	FREQ.DEC.POINT	0=88888, 1=8888.8, 2=888.88	
109		INPUT FREQUENCY	Digit 4	
110	55	INPUT FREQUENCY	Digit 3	
111			Digit 2	
112	56		Digit 1	
113			Digit 0	
114	57		DESIRED DISPLAY	Digit 4
115				Digit 3
116	58	Digit 2		
117		Digit 1		
118	59	Digit 0		
119		BATCH		0=no, 1=yes
120	60	BATCH LEVEL	Digit 4	
121			Digit 3	
122	61		Digit 2	
123			Digit 1	
124	62		Digit 0	
125			FILTER + RESET	bit 0 type of reset : 0=impulsional, 1 maintained bit 1 filter : 0=no, 1=yes
126	63	COUNTER OFFSET	Sign	
127			Digit 4	
128	64		Digit 3	
129			Digit 2	
130	65		Digit 1	
131			Digit 0	

132	66	CHRONOMETER OFFSET	Digit 4
133			Digit 3
134	67		Digit 2
135			Digit 1
136	68		Digit 0
137			PULSES PER REVOLUTION
138	Digit 3		
139	Digit 2		
140	70	Digit 1	
141		Digit 0	
142	71	PULSES PER CYCLE	Digit 4
143			Digit 3
144	72		Digit 2
145			Digit 1
146	73		Digit 0
147		AVERAGE TIME	Digit 2
148	Digit 1		
149	Digit 0		
150	75	TIME LIMIT	Digit 1
151			Digit 0
152	76	UPDATE TIME	Digit 1
153			Digit 0
154	77	SECURITY CODE	Digit 3
155			Digit 2
156	78		Digit 1
157			Digit 0

158	79	SOFT LOCK 1	bit 0 =setpoint 1 bit 1 =setpoint 2 bit 2 =setpoint 3 bit 3 =setpoint 4
159		SOFT LOCK 2	bit 0 =input bit 1 =display bit 2 =totalizer bit 3 =total lock-out
160	80	SOFT LOCK 3	bit 0 =analog output bit 1 =serial output bit 2 =logic inputs bit 3 =setpoint values (direct programming)
161		SOFT LOCK 4	bit 0 =reset key for process count bit 1 =reset key for total count bit 2 =reset key for batch count bit 3 =offset key operations
162	81	LOGIC FUNCTION CN2.1	0 to 29
163		LOGIC FUNCTION CN2.2	0 to 29
164	82	LOGIC FUNCTION CN2.4	0 to 29
165		LOGIC FUNCTION CN2.5	0 to 29
166	83	PRINT TIME/DATE + RESET VARIABLE	bit 0 =print date time bit 1 =reset process bit 2 =reset total bit 3 =reset batch
167		RESERVED	-
168	84	ADDRESS UNITS	0 to 9
169		ADDRESS TENS	0 to 9
170	85	RESERVED	-
171		BAUD RATE	1=1200, 2=2400, 3=4800, 4=9600, 5=19200
172	86	DELAY TIME RS485	1=30ms, 2=60ms, 3=100ms, 4=300ms, 5=no delay
173		PROTOCOL	1=ditel, 2=iso 1745, 3=modbus

## DYNAMIC VARIABLES (READ ONLY)

MODBUS	Variable	Meaning	Format
98	Peak	Internal peak reading	Floating (2 word)
100	Valley	Internal peak reading	Floating (2 word)
102	Frequency	Internal frequency/tachometer measurement value	Floating (2 word)
104	Process Count	Internal process count	Integer (2 word)
106	Totalizer Count	Internal total count	Integer (2 word)
108	Setpoint1	setpoint 1 value	Integer (2 word)
110	Setpoint2	setpoint 2 value	Integer (2 word)
112	Setpoint3	setpoint 3 value	Integer (2 word)
114	Setpoint4	setpoint 4 value	Integer (2 word)
116	Process Scale Factor	Scale factor for process display	Integer (2 word)
118	Totalizer Scale Factor	Scale factor for total display	Integer (2 word)
120	Setpoints and Logic Inputs Status (0=deactivated, 1=activated)	bit 0 = setpoint 1 bit 1 = setpoint 2 bit 2 = setpoint 3 bit 3 = setpoint 4 bit 4 = logic input 1 bit 5 = logic input 2 bit 6 = logic input 4 bit 7 = logic input 5	Byte
	Output Options (0=not installed, 1=installed)	bit 0 = 2RE bit 1 = 4RE bit 2 = RS2 bit 3 = RS4 bit 4 = - bit 5 = BCD bit 6 = ANA bit 7 = -	Byte

121	Version	'D'	Byte
		first version number	Byte
122		second version number	Byte
		third version number	Byte
123	Digits of the display	digit 0 (LSB)	Byte
		digit 1	Byte
124		digit 2	Byte
		digit 3	Byte
125		digit 4	Byte
		digit 5 (MSB)	Byte
126		digit 6 (LED's) bit 0 =SET 3 bit 1 =PROG bit 2 =RUN bit 3 =SET 2 bit 4 =SET 1 bit 5 =B bit 6 =A bit 7 =SET 4	Byte
		digit 7 (LED's) bit 0 = - bit 1 =STORE bit 2 =MIN bit 3 =MAX bit 4 =LIMIT bit 5 =HOLD bit 6 =TARE bit 7 = -	Byte

127	Over Process	0=no, 1=over	Byte
	Over Batch	0=no, 1=over	Byte
128	Over Total	0=no, 1=over	Byte
	Over Display Process	0=no, 1=over	Byte
129	Over Display Batch	0=no, 1=over	Byte
	Over Display Total	0=no, 1=over	Byte
130	-		
131	Batch Display	Batch counter display value	Integer (2 word)
133	Peak Display	Peak display value	Floating (2 word)
135	Valley Display	Valley display value	Floating (2 word)
137	Frequency Display	Frequency meter or tachometer display value	Floating (2 word)
139	Process Display	Process counter display value	Integer (2 word)
141	Total Display	Totalizer counter display value	Integer (2 word)
143	Offset	Offset value	Integer (2 word)









## INSTRUCTIONS FOR THE RECYCLING

This electronic instrument is covered by the **2002/96/CE** European Directive so, it is properly marked with the crossed-out wheeled bin symbol that makes reference to the selective collection for electrical and electronic equipment which indicates that at the end of its lifetime, the final user cannot dispose of it as unsorted municipal waste.

In order to protect the environment and in agreement with the European legislation regarding waste of electrical and electronic equipments from products put on the market after 13 August 2005, the user can give it back, without any cost, to the place where it was acquired to proceed to its controlled treatment and recycling.

### **DISEÑOS Y TECNOLOGIA, S.A.**

Polígono Industrial Les Guixeres

C/ Xarol 8 C

08915 BADALONA-SPAIN

Tel : +34 - 93 339 47 58

Fax : +34 - 93 490 31 45

E-mail : [dtl@ditel.es](mailto:dtl@ditel.es)

[www.ditel.es](http://www.ditel.es)