

SERIE KOSMOS

CODE: 30726293 EDITION: 07-06-2011



INSTRUCTIONS MANUAL



MICRA-D

COUNTER - TOTALIZER
TACHOMETER - TOTALIZER
FREQUENCY METER
CHRONOMETER



INDEX

1. OVERVIEW	4
1.1 Introduction to model Micra D.....	4
2. GETTING STARTED?	7
2.1 Dimensions and mounting	8
2.2 Programming guide.....	9
2.3 Power Supply. Connectors	11
2.4 Description functions keys and LED's in programming mode and mode RUN.....	12
2.5 Input signal (CN2) Connection	13
3. INPUT PROGRAMMING	14
3.1 Selection of sensor type	14
3.2 Diagram of programming mode: COUNTER	15
3.3 Counter configuration.....	16
3.4 Mode count programming	17
3.5 Programming of display.....	19
3.5.1 Options of the Process Variable	19
3.5.2 Brightness level configuration	19
3.5.3 Totalizer Option	20
3.5.4 Totalizer visualization	20
3.6. Programming diagram in MODE: CHRONOMETER	21
4. CHRONOMETER CONFIGURATION	22
4.1 Run mode programming.....	23
5. FREQUENCY METER / TACHOMETER CONFIGURATION	24
5.1 Frequencymeter / Tachometer.....	26
5.1.1 Frequencymeter	26
5.1.2 Tachometer RPM	26
5.1.3 Tachometer RATE.....	27
5.2 Display Setup	29
5.2.1 Options of the Process Variable	29
5.2.2 TOTAL, MAX and MIN visualization	31

6. LOGIC FUNCTIONS	32
6.1 Programmable functions table	33
6.1.1 Logic functions diagram	33
6.2 Program of functions	34
7. PROGRAM PARAMETERS AND KEYBOARD FUNCTIONS LOCK-OUT	35
7.1 Security menu diagram	36
8. RESTORATION TO FACTORY CONFIGURATION	38
9. OUTPUT OPTIONS	39
9.1 SETPOINTS OUTPUT	41
9.1.1 Introduction	40
9.1.2 Installation	42
9.1.3 Wiring	42
9.1.4 Technical specifications	43
9.1.5 Setpoints menu diagram in mode Frequncymeter / Tachometer	44
9.1.6 Direct access to the setpoints value programming	44
9.1.7 Description of operation in mode Frequncymeter, Tachometer	45
9.1.8 Setpoints menu Diagram in mode Counter / Chronometer	46
9.1.9 Description of mode relays operating as Counter / Chronometer	46
9.2 OUTPUT RS2/ RS4	48
9.2.1 Introduction	48
9.2.1 Diagram of the menu Input RS	49
9.3 ANALOG OUTPUT	53
9.3.1 Introduction	53
9.3.2 Installation of NMA or NMV option	53
9.3.3 Connection	54
9.3.4 Technical specifications	55
9.3.5 Analog output menu diagram	55
10. TECHNICAL CHARACTERISTICS	56
DECLARATION OF CONFORMITY	58
WARRANTY	59

1. OVERVIEW

1.1 Introduction to model Micra D

The MICRA-D model from the KOSMOS SERIE is a five-digit digital instrument with 2 programmable inputs that accept signals from a variety of standard sensors and pulse generators. Can be configured to work as:

- TACHOMETER + TOTALIZER (8 digits)
- TACHOMETER + DIRECTION OF ROTATION INDICATION
- FREQUENCYMETER
- COUNTER 5 digits + TOTALIZADOR (8 digits)
- SEVERAL MODES OF COUNTER (UP, DOWN, UP/ DOWN, PHASE)
- CHRONOMETER (5 digits)

The basic instrument is a soldered assembly composed of a main board, a **tricolor programmable display** and a power circuit.

Standard features of the basic instrument include the reading of the input variable as well as remote hold, reading and memorisation of max and min values (peak/ valley), tare and reset function, and a full complement of programmable logic functions.

MICRA-D model can also incorporate the following output options:

COMMUNICATION

RS2 Serial RS232C

RS4 Serial RS485

CONTROL

NMA Analogue 4-20mA

NMV Analogue 0-10V

2RE 2 Relays SPDT 8A

4RE 4 Relays SPST 5A

4OP 4 NPN output

4OPP 4 PNP output

All the output options are opto-isolated from input signal and power supply.

PROCESS COUNTER

UP counter, **DOWN** counter and bidirectional **UP/DOWN** counter

- In **UP/ DOWN** mode it can be programmed to work: Independent, Directional or Phase.
- Remote and front-panel reset
- Decimal point indication
- Reset may load a count value (OFFSET), programmable or entered from the display
- Multiplier/Divider factor from 0.0001 to 99999
- Programmable low frequency debounce filter (20 Hz) activates automatically when a contact closure input type is selected.
- Key-lock for RESET

TOTALIZER COUNTER

- Selectable totalizer with separate decimal point and scale factor independent from process counter.
- Count display from 99999999 to -9999999. Decimal point position programmable.
- Selectable 4 positions decimal point
- Input configuration and count mode is the same as selected for the process counter

- Alternating display of 4 digits high order part and 4 digits low order part of the value with corresponding indication H and L.
- No offset possibility
- Key-lock for the RESET function
- Remote and front-panel reset
- Scale factor from 0.0001 to 99999

CHRONOMETER

- Four ranges 999,99s, 999m59s, 999h59m, 9999.9h
- Remote and front-panel reset
- Reset may load a count value (OFFSET), programmable or entered from the display
- Counts UP or DOWN
- Key-lock for RESET

FREQUENCY METER / TACHOMETER

- Measures frequency, rpm, rate, flow and time.
- Decimal point indication
- Scale factor programmable from 0.0001 to 9999
- Display update time programmable from 0.1 to 9.9s
- Pulse arrival time limit programmable from 1 to 99.9s
- MAX and MIN values memorisation (TACHOMETER)

TACHOMETER WITH DIRECTION INDICATION

- The MICRA-D senses direction of rotation and indicates polarity of the signal by means of LED's represented by up and down arrows. This function requires programming the totalizer for up/down PHASE or DIREC mode.

TACHOMETER WITH TOTALIZER COUNTER

- The totalizer has the same scaling facilities as for the counter configuration thus allowing to have two simultaneous information of the same signal, for example speed and flow.

13 programmable logic functions operated at the rear connector enhance the functionality of the meter and allow controlling basic operations remotely.

In addition 18 commands through the serial port are available to allow reading and changing the setpoint values, request the display and reset to zero, etc...

Special software capabilities are program lock-out for individual menus or the entire program parameters, as well as the return to the factory configuration.

Programmable display color (red, green or amber) assignable to: programming, partial count value, total, setpoints, relay activation etc.



This instrument conforms the following community standards: 89/336/CEE y 73/23/CEE
Warning: Refer to the instructions manual to preserve safety protections.

2. GETTING STARTED

Packing contents

- ❑ Instruction manual in English including declaration of conformity
- ❑ Digital panel meter MICRA-D.
- ❑ Accessories for panel mounting (sealing gasket and fixing clips).
- ❑ Accessories for wiring connections (plug-in terminal block connectors with a fingertip key).
- ❑ Wiring label stuck to the MICRA-D case.
- ❑ 4 set of labels with engineering units.
- ✓ ***Check the packing contents.***

Programming instructions

- ❑ The Instrument includes software that allows, via keyboard, accessing to several independent programming menus for configuration of the input, the display and the logic functions. If additional options are installed (serial outputs, analogue output and relays output, once recognised by the instrument, they activate their own programming software.
- ✓ ***Read carefully this section.***

Programming lock-out (Page 35).

Software allows total programming lockout but also selective lockout of the programming parameters.

- ❑ The instrument is delivered from factory with unlocked programming, e.g., with all the programming levels accessible to the operator

Write down the security code and keep it in a secure place.

The figure below shows the locations of the different output options available.

The **2RE**, **4RE**, **4OP** y **4OPP** options are alternative and only one of them can be installed in the M1 connector.

The **RS2** y **RS4** options are also alternative and only one of them can be installed in the M2 connector.

The **NMA** or **NMV** are also alternative and only one of them can be installed in the M3 connector.

Up to three output options can be installed and operate simultaneously:

- 4-20mA or 0-10V (only one)
- RS232C or RS485 (only one)
- 2 RELAYS, 4 RELAYS or 4 OPTO (only one).

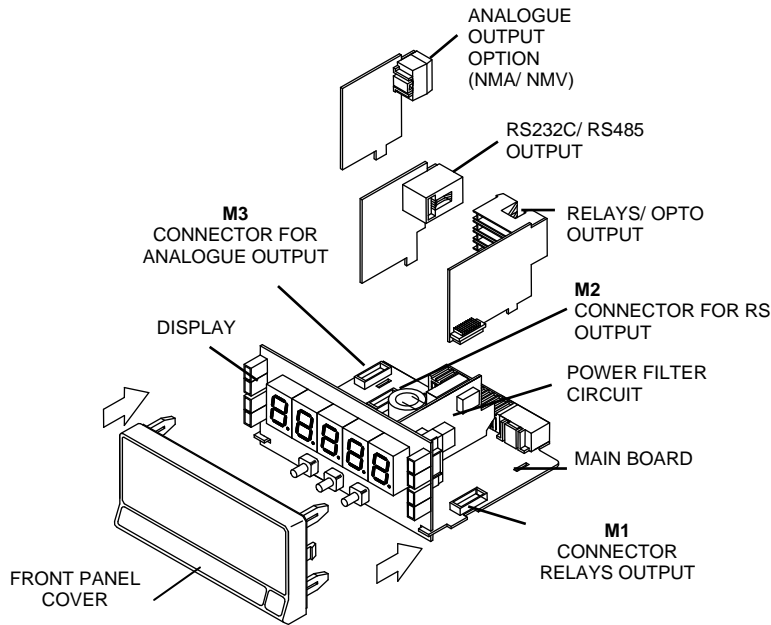

2.1 Dimensions and mounting

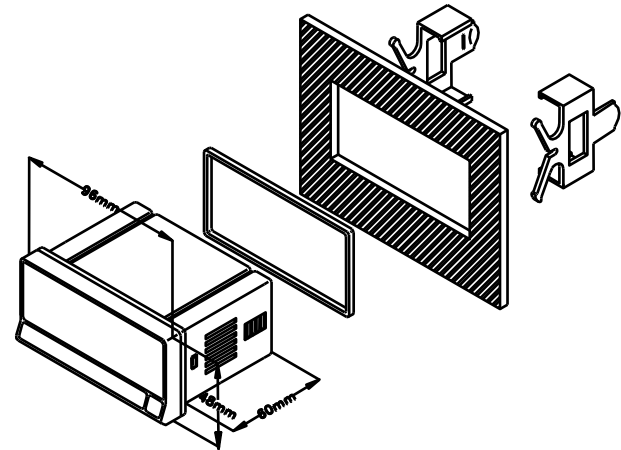

Front: 96 x 48 mm Depth: 60 mm
Panel cut-out: 92 x 45 mm

CLEANING: frontal cover should be cleaned only with a soft cloth soaked in neutral soap product.
DO NOT USE SOLVENTS

2.2 Programming guide



How to get into programming mode?

First, plug the instrument to the corresponding supply, automatically a display test will be done and after that the software version will be shown then the instrument will go to work mode. Second, press the  key to enter into the programming mode, the indication "-Pro-" will appear on the display then.

How to store programmed parameters?

If we want to save the changes that we have done in the programming, we must complete the programming of all the parameters contained in the routine we are in. In the last step of the routine, as a result of pressing on the  key, "StorE" will be displayed during a few seconds, meanwhile all the data are stored in memory. Then the instrument will go back to working mode.

How is programming routine organised?

Programming software is composed by a number of menus and submenus hierarchically organized. On figure below, beginning with indication "-Pro-", press repeatedly  to get access to programming menus. Modules 3, 4 and 5 will only be shown if the option for setpoints, analogue output or RS option has been plugged in. Selecting one menu, the access to the different programming submenus is done by pressing .

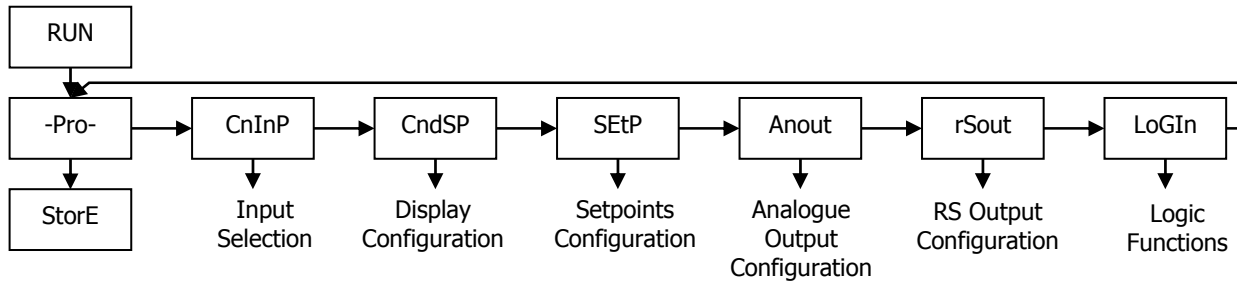



Module selection level

Accessing to programmed parameters

Thanks to the tree structure, the programming routines allow to access to one parameter and modify it without passing through the whole list of parameters.

To advance through programming

The progress through the programming routines is done by pressing  key.

In general, the steps to be done will be push  key a certain number of times to select an option and push  key to validate the change and going forward to the next step of the program.

The numerical values are programmed digit by digit as explained in the next paragraph.

Programming numerical values

When the parameter is a numerical value, the first of the digits to be programmed will appear blinking on display.

The method of introducing a value is as follow:

Digit selecting: Press repeatedly the  key to shift from left to right over all the display digits included the LED direction indicators (when the programmed function requires it).

Changing the digit value: Press repeatedly the  key to increase the value of blinking digit until it has the desired value or to alternate the LED Up and Down arrows indicators (MAX and MIN).

Selecting an option from the list

When the parameter is an option to be chosen among different possibilities, the  key allows you to browse through the list of options until you find the desired parameter

2.3 – Power supply and connectors

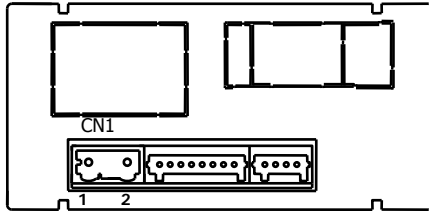
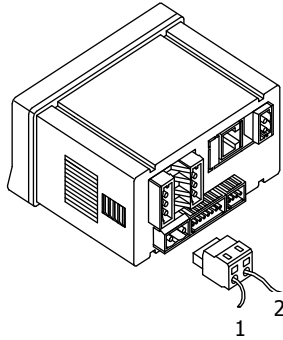

WIRING and POWER SUPPLY RANGE

MICRA-D

85 V – 265 V AC 50/ 60 Hz or 100 – 300 V DC

MICRA-D6

22 – 53 V AC 50/ 60 Hz or 10,5 - 70 V DC

Borne 1: Phase

Borne 2: Neutral

NOTE: When DC power supply (direct) polarity in connector CN1 is indistinct.

WARNING: If not installed and used in accordance with these instructions, protection against hazards may be impaired.

In order to guarantee the electromagnetic compatibility, the following guidelines should be kept in mind:

- Power supply wires may be routed separated from signal wires.
- Never run power and signal wires in the same conduit.
- Use shielded cable for signal wiring and connect the shield to the ground.
- The cables section should be $>0.25 \text{ mm}^2$

INSTALLATION

To meet the requirements of the directive EN61010-1, where the unit is permanently connected to the mains supply, it is obligatory to install a circuit breaking device easy reachable to the operator and clearly marked as the disconnect device.

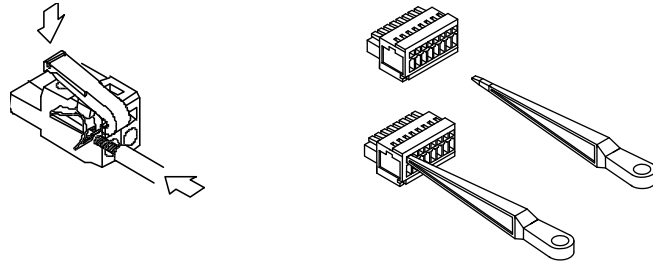

CONNECTORS

CN1 To perform wiring connections, strip the wire leaving from 7 and 10 mm exposed to air and insert it in the proper terminal while pushing the fingertip down to open the clip inside the connector as indicated in the figures. Each terminal accepts cables of section between 0.08 mm^2 and 2.5 mm^2 (AWG $26 \div 14$).

2.4 Functions keys and LED's description in programming mode and RUN mode

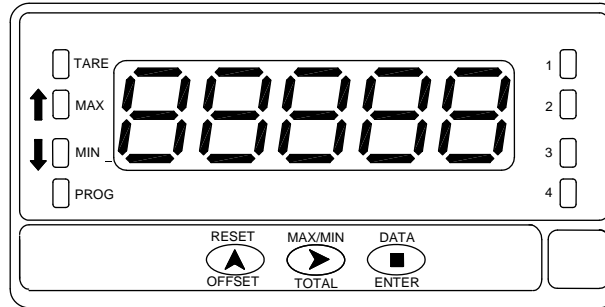

KEY	Function in programming mode
DATA ENTER	- to step forward in programming menu - to validate programmed values - to exit programming menu
MAX/ MIN TOTAL	- to move blinking digit
RESET OFFSET	- to increase blinking digit value - Direct access to Setpoints value
LED's	Function in programming mode
TARE	
MAX	Indicates rotation sense (polarity)
MIN	Indicates rotation sense (polarity)
PROG	Indicates you are in programming mode
1- 2 - 3 - 4	Indicates the Setpoint that is being programmed

KEY	Function in RUN mode
DATA ENTER	- to enter programming menu or to visualize parameters if programming is locked
MAX/ MIN TOTAL	1st stroke allows TOTALIZER visualization (if activated) 2nd stroke allows Max visualization (only Tachometer) 3ª stroke allows Min visualization (only Tachometer) Following stroke: back to current value.
RESET OFFSET	In Tachometer mode reset of MAX/ MIN/ TOTAL (if present on display) In Counter mode Reset / OFFSET (starts measuring)
LED's	Function in RUN mode
TARE	Indicates that there is an offset value programmed
MAX	Fixed indicates rotation sense or count polarity Blinking indicates visualization of a Max value
MIN	Fixed indicates rotation sense or count polarity Blinking indicates visualization of a Min value
PROG	Not active in run mode
1- 2 - 3 - 4	Indicates the activated Setpoint

2.5 – Input signal (CN2) Connection

Refer to connection recommendations on page 11

Instrument's rear view

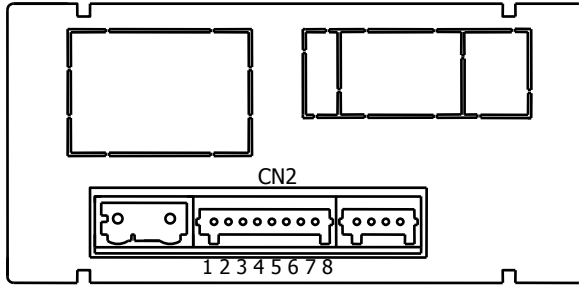

CN2

- PIN 1 = No Connection
- PIN 2 = (+) 18 V Excitation
- PIN 3 = (+) 8,2 V Excitation Namur sensors
- PIN 4 = (-) Common excitation / input
- PIN 5 = Signal B input
- PIN 6 = Signal A input
- PIN 7 = No Connection
- PIN 8 = High voltage input (300 Vac max.)

MAGNETIC PICKUP

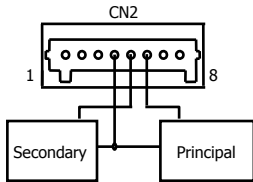

CONTACT CLOSURE

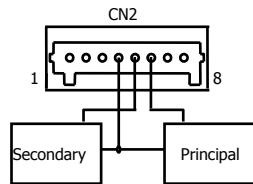

PNP/ NPN SENSOR

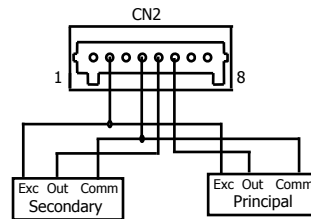

NAMUR sensor

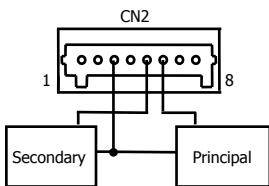

ENCODER

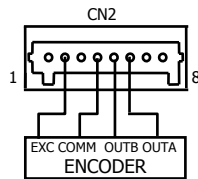

10- 300 Vac

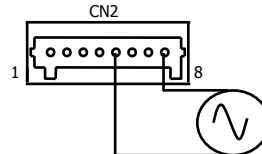

3. INPUT PROGRAMMING

3.1 Selection of sensor type

The diagram below shows first the configuration menu of the different sensors types, next step is then going to the run mode selection.

When selecting Contact closure sensor type, anti rebound filter will activate automatically
Both input channels are programmed automatically for the same type of sensor input.

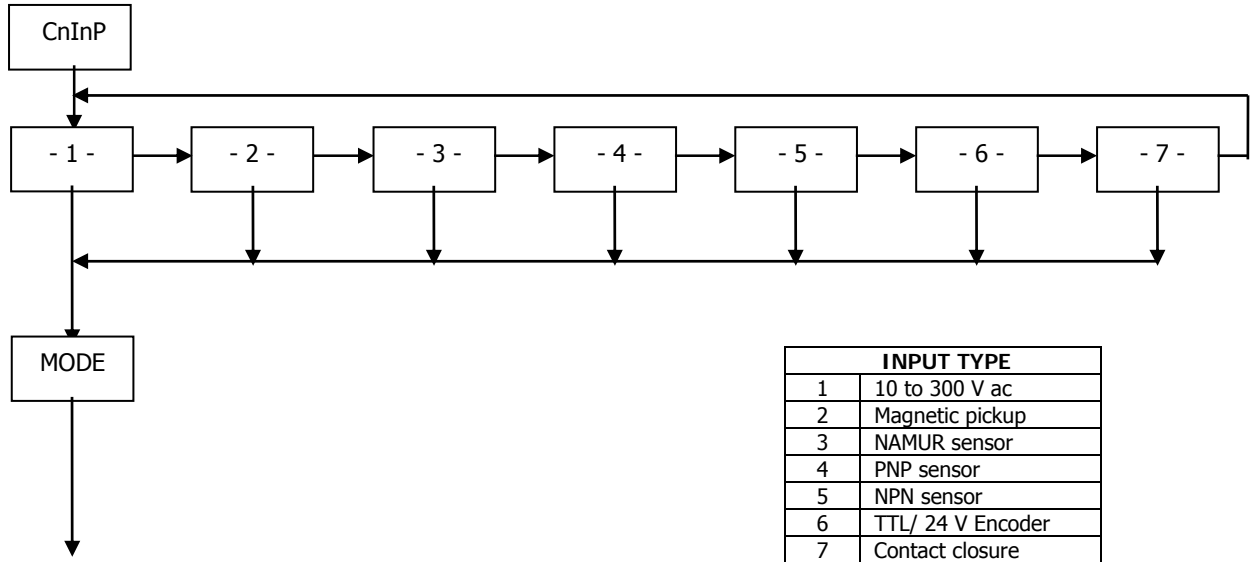

3.2 COUNTER mode programming diagram

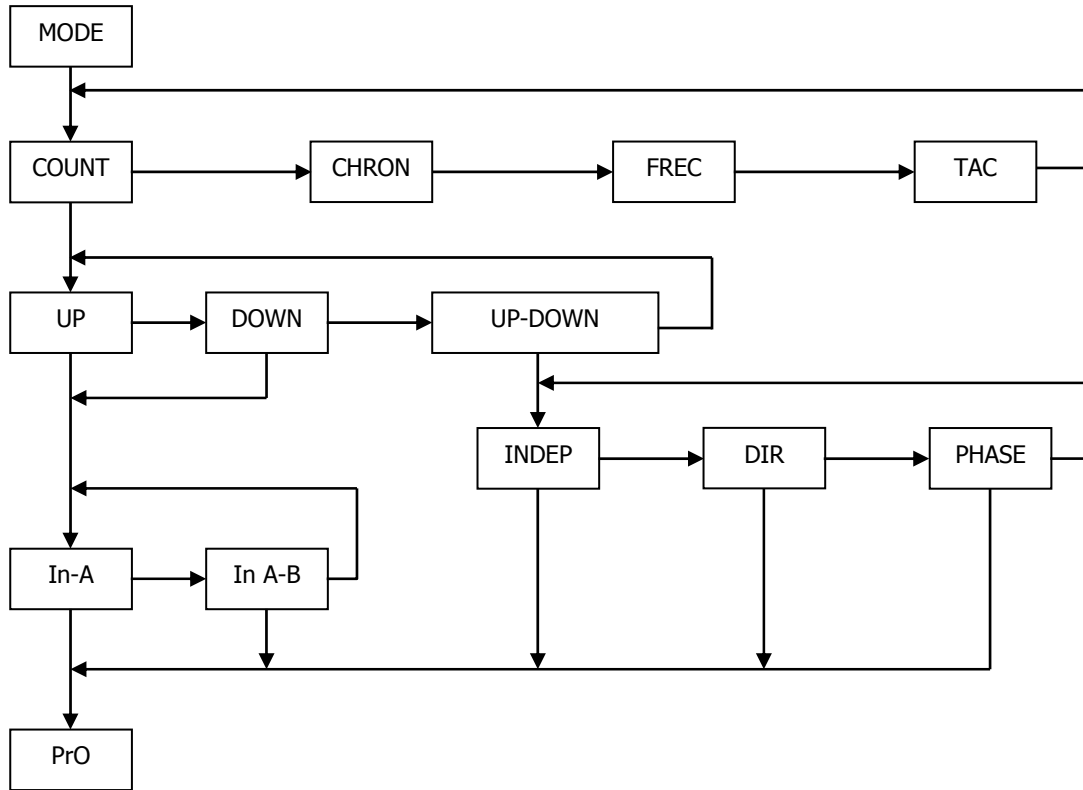

3.3 Counter configuration

INPUTS

The counter has two inputs, the A input receives the pulses to count, and the B input serves to inhibit the count or to change the count direction, except in case of bidirectional counter **IndEP** where the second input is also used to count pulses.

PULSE MEASUREMENT

The pulses applied to the input are detected in the rising edge and immediately update the value of the counter and the setpoints status if the card is installed. The display updates every 100 ms. In a power failure or disconnection from the supply source, the instrument keeps the count values.

VARIABLES

The main variable of the counter is the PROCESS variable that is the number of pulses registered from the last RESET operation.

If the totalizer option is enabled, we have PROC and TOTAL variables.

The TOTAL variable counts the total number of pulses received, independently of the reset operations that may take place in the process display.

DISPLAY

Process: The limits of the display are 99999 and -99999. When the instrument exceeds 99999, it shows OVER, and when it falls below -99999, it shows UNDER. The positive sign is indicated by the red LED Up arrow located on the left side of the display and the negative sign is indicated by the red LED Down arrow located on the left side of the display.

The decimal point can be located in anyone of the digits of the display, and it has not value, that is, the display always shows the whole part of the measurement.

Total: The limits of the display are 99999999 and -99999999. When the instrument exceeds these limits the display shows the indications OVER or UNDER. The negative sign, when the value has less than five digits, appears in the most significant digit of the display.

The negative sign is indicated by the MIN LED.

When the total value has more than five digits, the display alternates the 4 digits high order part and the 4 digits low order part (the letters 'H' and 'L' in the auxiliary digit indicate which part is on display).

The decimal point can be located in anyone of the digits of the low part, and it does not have value, the display shows the whole part of the measurement.

3.4. Mode count programming

The input setup is available on the 'CnInp' module which allows configuration of the count mode and batch operation.

3.1.1. Count Modes

The software provides setup for five different count modes:

uP

Up count

do

Down count.

In-A

Allows count on A input regardless of input B

InA-B

Pulses applied at the A input are added or subtracted to the count display if the B input is at low level and being used as inhibited input.

uP-do IndEP

Pulses applied at the A input are added to the count display while pulses at the B input are subtracted.

uP-do dIrEC

When B input is at low level, the pulses applied at the A input increment the count. When B input is at high level, the pulses at the A input decrement the count.

uP-do PHASE

The rising edges at the A input increment the count if the B input is at low level. The falling edges at the A input decrement the count if the B input is at low level.

Unidirectional counters:

MODE uP InA-B

A counts up if B is '0'. B inhibits count.

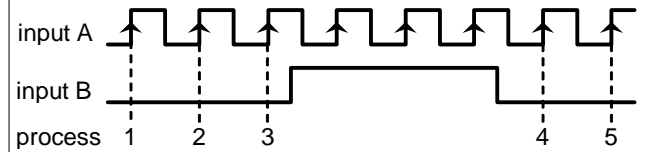

MODE do InA-B

A counts down if B is '0'. B inhibits count.

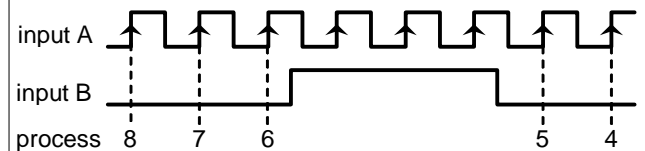

Bidirectional counters:

MODE uP-Do INDEP

A counts up. B counts down.

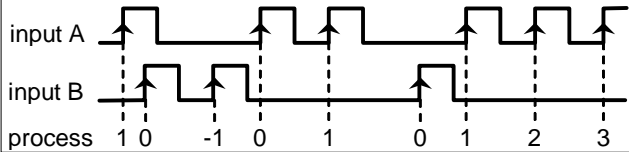

MODE uP-Do DIREC

A counts up if B is '0' and counts down if B is '1'

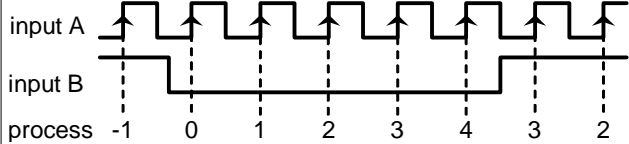

MODE uP-Do PHASE

Rising edge of A counts up if B is '0'. Falling edge of A counts down if B is '0'.

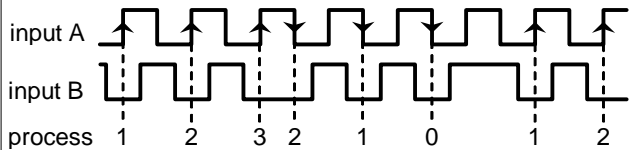

Programming diagram of the DISPLAY in MODE: COUNTER

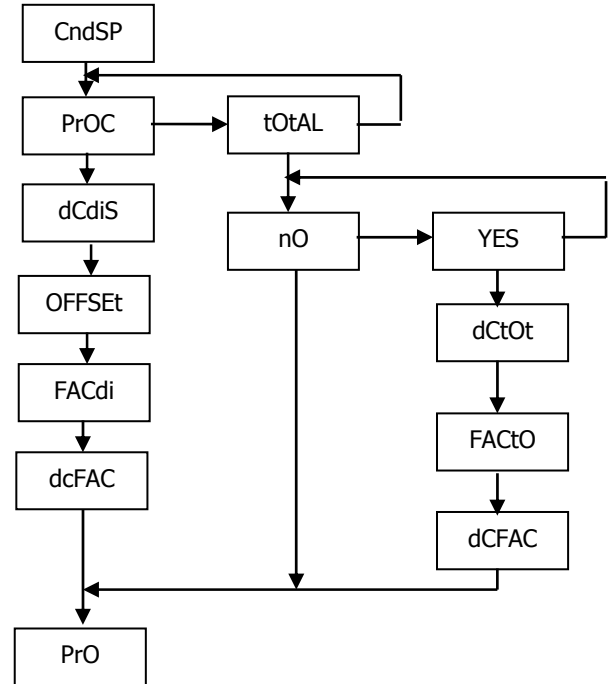

3.5. Scaling Setup

3.5.1. Options of the Process Variable

In the menu **ProC** of the **CndSP** module can be found the parameters related to the **PROCESS** variable measurement, - Decimal Point, Offset, Multiplier Factor-

DECIMAL POINT

The decimal point indication helps to read the display in the desired engineering units.

The decimal point has no real value, i.e. the digits to the right of the decimal point are not actually decimals. To read values with resolution to the desired decimal places is achieved by a combination of decimal point and scaling factor.

For example, suppose a system that provides 100 pulses per 2 meters length of a material. To display length in meters and centimeters, you should program a factor of 2 (1 pulse = 2 cms) and place the decimal point to the third digit.

OFFSET

OFFSET is the value that takes the counter in a reset event.

By default it is zero whatever is the configuration.

Configurable in the menu **ProC**

The OFFSET is applied to the **PROCESS** variable exclusively.

When the OFFSET is different from zero, the LED TARE will remain active while in the run mode.

SCALE FACTOR

The scale factor is programmable from 0.00001 to 99999.

Individual decimal point location makes possible to program any value within this range independently from the main decimal point of the display.

Any number below 1 act like a divisor while a number above 1 acts like a multiplier. (It is not possible to program a factor=0).

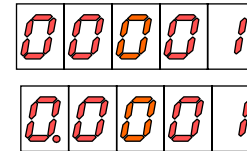

3.5.2 Configuration of display brightness level

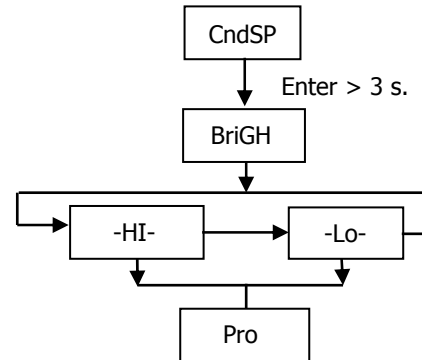

3.5.3. Totalizer Option

The totalizer facility can be enabled and disabled by software.

The totalizer counter shares the same input setup, count mode and count direction as the process counter but provides separate decimal point and scaling factor.

Each pulse received at the input increment or decrement the process and total counters exactly, although the display value may vary from one to another according to individual scaling factor and reset operations.

The limits of the display are -9999999 and 99999999 (7 digits with minus sign or 8 digits).

The decimal point can be set to five decimal places.

The scaling factor is programmable between 0.00001 and 99999 as for the process counter.

The totalizer has no possibility to load a user selected display value in a reset event.

3.5.4. Totalizer visualisation

The total value accumulated since the last reset will be displayed in the format indicated hereafter, when pressing on key TOTAL (if activated).

DISPLAY FORMAT

When the total value is between -9999 and 99999, it is shown on the display with the letter 'L' in the auxiliary digit and with the red led up and down arrows for positive and negative.

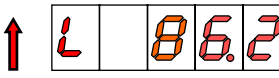
(positive) 

(negative) 

When the accumulated value exceeds from four digits, the display alternates a 4 digit high order part (with the letter 'H' in the auxiliary digit) and a 4 digit low order part (indicated by the letter 'L' in the auxiliary digit).

(The switching between high and low order parts takes place at a rate of approximately 2s each part).

3.6. Programming diagram in MODE: CHRONOMETER

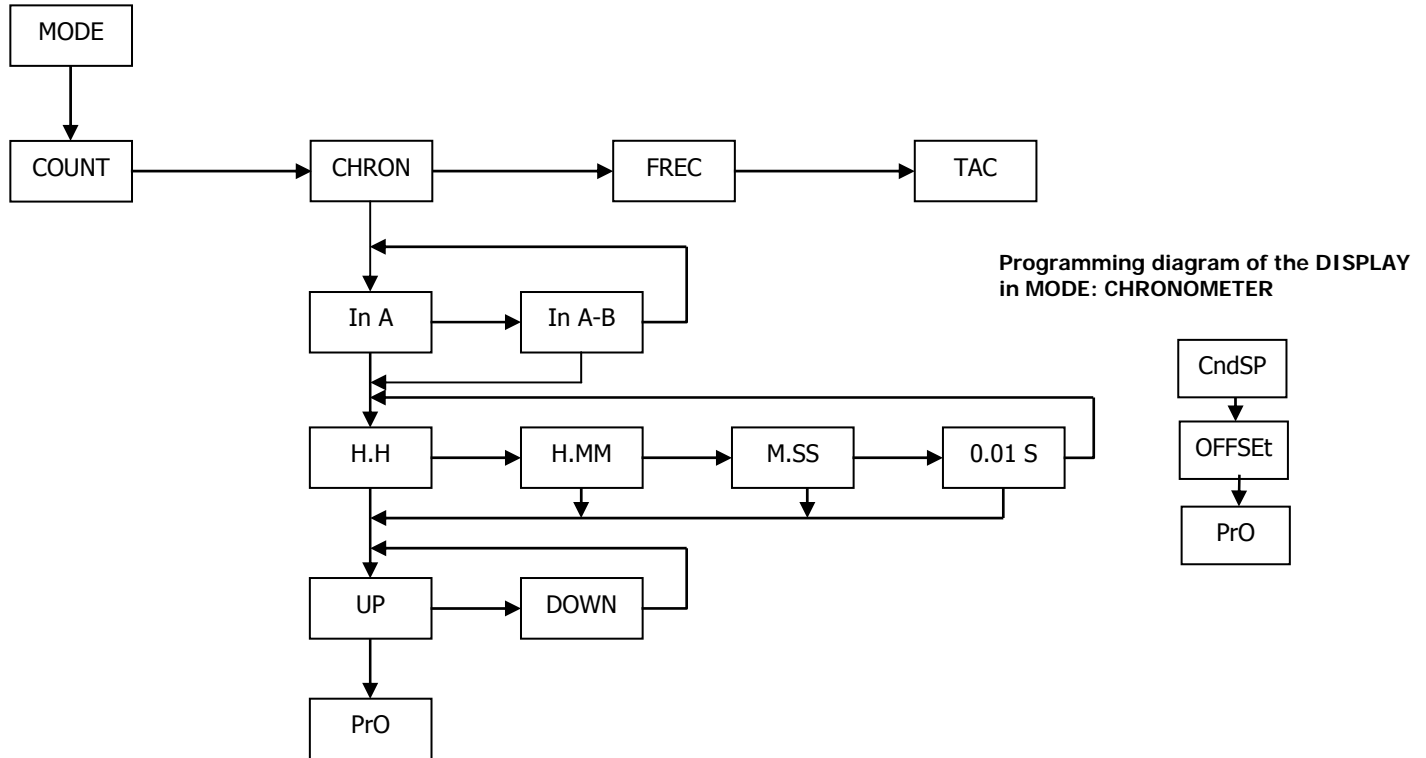

4. CHRONOMETER CONFIGURATION

INPUTS

The meter has two inputs for the START and STOP signals that provide different types of time measurement according to input setup (see page 23 "Start and Stop Modes").

There are three selectable operating modes:

mode In-A, that allows to measure the width of a pulse,

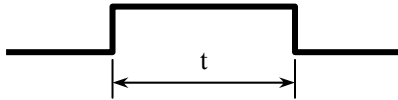

and **mode In-AB**, that is used to measure the difference between two signals

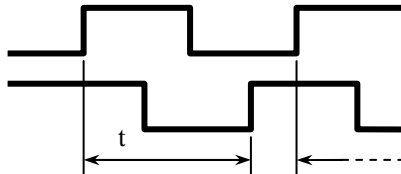

MEASURE

Time measurement is initiated on a rising edge of the START input. This starts up an internal counter which is controlled by a high precision crystal quartz clock.

The STOP signal suspends the internal count keeping the value of the counter to the START of following time measurement cycle.

The counter is missed to zero in a RESET operation.

In a disconnection from the power source, the instrument saves the count value reached internally.

DISPLAY

The display can not be scaled, it only reads time in the units selected according to the programmed time range.

The decimal point appears at a fixed position according to time range.

OFFSET

An offset value can be programmed for example to count down to zero from the preset time value.

The measured value, and the alarms if they exist, is updated in each minimum unit of the selected magnitude.

Display refreshment: each 100ms.

4.1. Input Setup

START AND STOP MODES

MODE In-A START on rising edge of input A.
STOP on falling edge of input A.

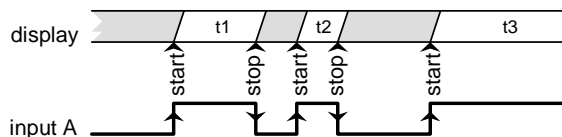

MODE In-AB START on rising edge if input A.
STOP on rising edge of input B.

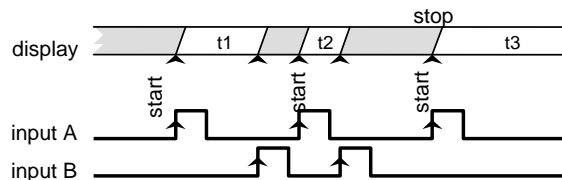

UP or DOWN DIRECTION

uP : The meter acts as a stopwatch. It counts up the time elapsed between the START and STOP signals. When accumulated value exceeds from 99999, the display reads OVER.

do : The meter acts as a timer. It counts down from a user programmed offset to zero (a setpoint may be used to perform any function at this point). A reset operation sets the timer to the offset value; the START signal initiates the timing count. When accumulated value reaches 0, the next decrement makes the display read UNDER.

TIME RANGE

There are four selectable time ranges:

- H.H** 9999.9 h (resolution 0.1 hours)
- H.MM** 999 h 59 m (resolution 1 minute)
- M.SS** 999 m 59 s (resolution 1 second)
- 0.01-S** 999.99 s (resolution 0.01 second)

The decimal point appears in the position according to the programmed time range.
(In a power failure, the meter saves the time value and the internal count value).

5. FREQUENCY METER / TACHOMETER CONFIGURATION

INPUTS

In frequency/tachometer mode both inputs of the meter are used. The signal providing frequency/rate and count information must be issued to the A input. A second signal may be applied to the B input to control direction of rotation or polarity of the signal.

MEASURE

The method of calculating rate is based in measuring the period of the signal, that is, the time elapsed between two consecutive rising edges. The period is converted into a high precision frequency value and scaled to read desired units.

DISPLAY

The meter allows the user to change some parameters to fit the particular application needs, such as to reduce or extend the number of signal cycles of each reading, the time limit, the display rate and averaging (see "Options of the Process Variable" in pages 29 and 30).

TOTALIZER

If enabled, the totalizer accumulates the number of pulses received at the input providing two simultaneous information for example flow rate and product quantity for a given process.

DIRECTION OF ROTATION INDICATION

Direction sensing indication is a matter of simply setting the totalizer to read UP/DOWN direction (modes PHASE and dIrEC).

The direction of rotation is denoted by the LED's MAX and MIN on the left of the display. LED MAX illuminates when the totalizer counts in the up direction, so it can be associated to a "positive" rate. LED MIN illuminates when the totalizer counts down, which may be associated to a "negative" rate.

A change in the polarity of rate is recognized when the meter receives at least two consecutive pulses in the opposite direction of the one of the previous pulses.

**Programming diagram for MODE:
FREQUENCYMETER/ TACHOMETER**

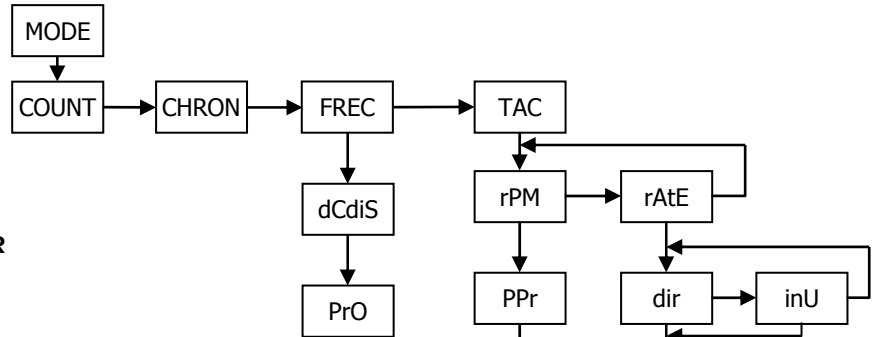

**Programming diagram of the DISPLAY in
mode: FREQUENCYMETER / TACHOMETER**

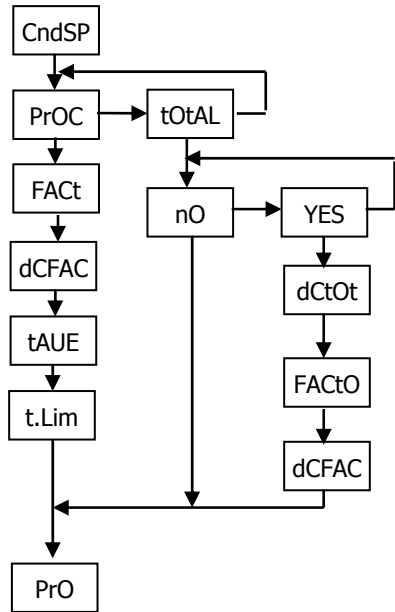

5.1. Frequencymeter / Tachometer

CONFIGURATIONS

The different configurations allow measurement of almost any process quantity based in frequency calculation.

5.1.1. Frequencymeter

To use this instrument as frequency indicator, select directly the frequencymeter input.

DECIMAL POINT

The only parameter to select in this input menu is the position of the decimal point, which can be 0, 1 or 2. The decimal point position determines the max. and min. frequencies visible on display; with two decimals, max. frequency will be 999.99Hz and min. frequency 0.01Hz, with one decimal, max. frequency will be 9999.9Hz and min. frequency 0.1Hz, and with no decimal, max. frequency is limited according to the selected options (see technical features in page 56) and min. frequency will be 1Hz.

5.1.2. Tachometer for RPM

In this configuration the meter reads rotational rate in revolutions per minute (RPM). The tachometer is configured by entering the number of pulses per revolution and the decimal point location.

PPR (PULSES PER REVOLUTION)

The PPR parameter is the actual number of pulses that a sensor connected to a wheel gives to the input of the meter in a rotation of the wheel.

The method of measurement is based in calculating the time necessary for the system to produce a complete rotation of the wheel, therefore, by default each reading extends over the programmed number of pulses.

DECIMAL POINT

The decimal point location, in combination with a suitable scale factor allows the display reading be expressed into other units different from RPM if desired.

5.1.3. Tachometer Rate

In this configuration the meter can be easily scaled to read direction, speed, flow or time directly in the desired units by entering only two parameters: Input Frequency and Desired Display.

DIRECT OR REVERSED SCALING

Direct scaling. The relationship between frequency and display is directly proportional, that is, the higher the frequency, the greater the display. This will be the mode to choose in most applications.

Reversed scaling. The relationship between frequency and display is reversed, that is, the higher the frequency, the lower the display. A typical application of this mode is explained in the example of page 28.

The scaling procedure consists of entering a display value corresponding to an input value. A straight line plotted from this point to zero (input=0, display=0) establishes a linear relationship between frequency and display.

INPUT FREQUENCY

For scaling purposes, the input frequency value can be programmed within all range of the display (the frequency limits are given in page 57 of the present manual).

The input frequency can be programmed with 0, 1 or 2 decimal places. The decimal point position has value, for example, a frequency value of 200Hz can be programmed as 200, 200.0 or 200.00

DESIRED DISPLAY

In this phase it is programmed the display value corresponding to the programmed input frequency. The decimal point can be located in any of the digits of the display to help reading the display in the desired units.

EXAMPLE OF SCALING IN RATE MODE

Loaves of bread are transported in a conveyor belt and introduced in a continuous baking oven. The belt is attached to a turning shaft of 20cms that gives 6 pulses per revolution. The average time necessary for a loaf to be baked is 15min and 30s and it has been determined that, to achieve this time, the rate of the turning shaft must be kept to 300rpm. This example allows exposing some capabilities of the rate meter configuration.

The rate of the turning shaft is 300 revolutions per minute, which is equal to 5 revolutions per second.
If the turning shaft makes 5 complete revolutions in one second and each revolution drives out 6 pulses, the total number of pulses per second is 30. The input frequency is then 30Hz.

Rate of the conveyor belt (m/s)

The rate of the conveyor belt at the specified frequency is:
 $\text{rpm} * \pi * \text{diameter} = 300 * \pi * 20 = 18849.6 \text{ cm/min}$ which is in m/s, 3.142m/s.

PARAMETERS TO PROGRAM:

RATE MODE:	DIRECT
INPUT FREQUENCY:	30
DESIRED DISPLAY:	03142
DECIMAL POINT:	03.142 (m/s)

Baking Time (min)

It is required to monitor the baking time knowing that, at the specified frequency of 30Hz, the time taken for each loaf to be baked is 15min 30s.

When rate (and frequency) grows, the baking time is reduced proportionally. The rate meter must then be programmed for reverse mode.

PARAMETERS TO PROGRAM:

RATE MODE:	INVERSE
INPUT FREQUENCY:	30
DESIRED DISPLAY:	00155
DECIMAL POINT:	0015.5 (min)

The time values must be programmed in decimal notation.

In the preceding example, a baking time of 15min 30s has been introduced as a display value of 15.5 (15 minutes and a half).

Daily Production (loaves/day)

It has been determined that, in the specified conditions, the bread loaves are baked at an average of 10 loaves per minute. The baking oven works 12 hour per day and it is required to monitor the production of loaves per day.

Ten loaves per minute is equivalent to $10 \times 60 = 600$ loaves per hour.

At a frequency of 30Hz, the daily production is $600 \times 24 = 14400$ loaves/day.

PARAMETERS TO PROGRAM:

RATE MODE:	DIRECT
INPUT FREQUENCY:	30
DESIRED DISPLAY:	14400
DECIMAL POINT:	NO

5.2. Display Setup

5.2.1. Options of the Process Variable

The menu **ProC** in the module **CndSP** contains various parameters for scaling and filtering the display -Scale Factor, Max and Min Times, Averaging-.

SCALE FACTOR

The scale factor is programmable between 0.0001 and 9999 and multiplies or divides depending on if it is higher or lower than 1.

For example, it can be used to change display units, rpm instead of rps.

TIME LIMIT

The time limit, programmable from 1 to 99 seconds, is the amount of time that the meter waits for at least one pulse is produced at the input before it is considered to be zero.

The time limit is initialized at the reception of each input pulse. If no more pulses are detected before the time limit runs out, the display is forced to zero.

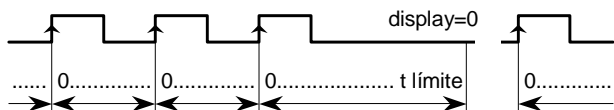

Decreasing the limit time makes the instrument respond more quickly to the zero condition when the system stops.

Nevertheless, this reduction also will cut the lowest frequencies (for example: with a time limit of 10s, it would be impossible to see frequencies under 0.1Hz and with a time of 1s, frequencies under 1Hz).

AVERAGE TIME

The average time is a time interval in seconds during which all readings calculated from the input are averaged.

The average time is programmable from 0 to 9.9 seconds.

To disable this feature program 0.

When the display presents unwanted variations, due to that the input signal is not regular, the programming of the average time for a larger value may help stabilize the display.

The average time can be calculated for a desired number of readings knowing the signal frequency.

Example: With a setup of 0.1s, if the input signal frequency is of approx. 10Hz or less, the meter will only take one reading per each 0.1s making no average. With an input signal of approx. 100Hz, the meter will be able to collect and average about 10 readings in 0.1s. If the input signal is of approx. 1000Hz, the display will read out the average of about 100 readings.

IMPORTANT: Direction sensing indication is achieved by selecting one of the bidirectional count modes PHASE or dIrEC.

"Positive sign" indication occurs when the pulses applied to the instrument increase the counter while "negative sign" indication occurs when the input pulses decrement the counter.

A change in the polarity of rate is recognized when the meter receives at least two consecutive pulses in the opposite direction of the one of the previous pulses.

DECIMAL POINT

The decimal point indication helps to read the display in the desired engineering units.

The decimal point has not real value, that is the digits to the right of the decimal point are not actually decimals. To read values with resolution to the desired decimal places is achieved by a combination of decimal point and scaling factor.

SCALE FACTOR

The scale factor is programmable from 0.0001 to 99999. Individual decimal point location makes possible to program any value within this range independently from the decimal point of the display. Any number below 1 acts like a divisor while a number above 1 acts like a multiplier.

RESET KEY

The RESET key allows, in **Tachometer** mode, setting the Max and Min memories to the current value.

To set the MAX or MIN value to the current value, the value you want to reset must be showed on display and pressing on the reset key will erase this value.

To reset the **totalizer** it is necessary to recall the TOTAL variable on display pressing TOTAL key and then press RESET.

Clear to zero the variable present on display is carried out when releasing the RESET key; being then reinitiated the count, in **counter** mode or **chronometer**, from zero or offset.

The RESET key will not operate if in the program lock-out routine its corresponding step is activated.

5.2.2 TOTAL, MAX and MIN Visualization

In **tachometer mode** one push on the MAX/ MIN key shows, when activated, the total value in the programmed color; next push shows the peak value with the flashing led MAX indicator; next push shows the valley value with the flashing led MIN indicator; another push brings us back to current value indication.

6 – LOGIC FUNCTIONS

The rear connector CN3 provides 3 user programmable opto-coupled inputs that can be operated from external contacts or logic levels supplied by an electronic system. Three different functions may be added to the functions available from the front-panel keys. Each function is associated to one pin (PIN 2, PIN 3, PIN 4) and is activated by applying a falling edge or a low level pulse to the corresponding pin with respect to common (PIN 1).

Each pin can be assigned one of the 13 functions listed on the following pages.

- Factory configuration

Functions associated to Connector CN3 in factory configuration are: OFFSET, RESET and RESET TOTALIZER.

CN3: FACTORY CONFIGURATION

PIN (INPUT)	Function	Number
PIN 1	COMMON	
PIN 2 (INP-1)	OFFSET	Function nº 1
PIN 3 (INP-2)	RESET	Function nº 2
PIN 4 (INP-3)	RESET TOTALIZER	Function nº 6

Logic functions diagram

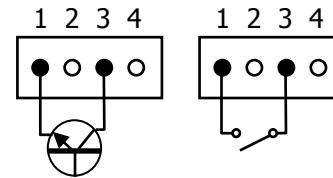

The external electronics applied to the CN3 connector must be capable of withstanding 40 V and 20 mA present at all terminals with respect to COMMON. In order to guarantee the electromagnetic compatibility, please refer to the instructions given on page 9.

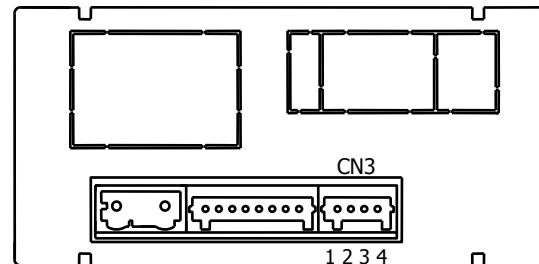

6.1.1 – Logic functions diagram

6.1 – Programmable functions table

- **Nº:** Number to select the function via software.
- **Function:** function name.
- **Description:** Function operation and characteristics.
- **Activation by :**

Falling edge: the function is activated applying a falling edge to the corresponding pin with respect to common.

Low level: The function will remain activated as long as the corresponding pin is held at a low level.

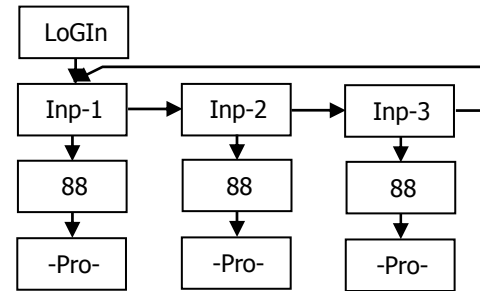

Nº	Function	Description	Activation by
0	Deactivated	None	None
1	OFFSET	Adds the current display value to the offset memory and sets the display to zero.	Falling edge
2	RESET	Sets to zero the partial counter value (Proc)	Falling edge
3	MAX	Displays the peak value. (MÁX.) In Tachometer mode.	Low level
4	MIN	Displays the valley value. (MÍN) In Tachometer mode.	Low level
5	RESET MAX/ MIN	Clears the peak or valley readings (the one shown in the display).	Falling edge
6	RESET TOTALIZER	Sets the TOTALIZER to zero.	Low level
7	PRINT PROCESS	Sends the partial counter value (Proc) to printer	Falling edge
8	PRINT TOTAL	Sends the total value to printer	Falling edge
9	PRINT OFFSET	Sends the offset value to printer	Falling edge
10	ASCII	Sends the last four digits to a MICRA-S. By holding the input to a low level, transmission takes place every second	Falling edge / Low level
11	BRIGHTNESS	Change the display brightness from Hi to Low	Low level
12	SETPOINT VALUE	Displays the selected setpoint value (see diagram next page)	Low level
13	False Setpoints	Simulates that the instrument has a four setpoints option installed	Low level

6.2 – Program of functions

0 to 13

t-off t-on-

Once the user has accessed the menu of logic functions configuration, he can select, by pressing the  key, a function among those of the table.

If the user selects any of the logic functions 7, 8 or 9, the instrument will display any of these 2 messages. The second, when activated the corresponding function, will add to the corresponding value sent to the printer the order to print date and time.

Example: MICRA-D with value of 1234.5

Message in Hexadecimal sent from the MICRA-D RS4 output when logic function 7 is activated.

With *t-off* the chain of characters is: **0x18, 0x23, "01", 0x0D, "NET: +1234.5", 0x0D**

With *t-on-* the chain will be: **0x18, 0x23, "01", 0x0D, "NET: +1234.5", 0x0D, 0x18, 0x4A, 0x06, 0x18, 0x48**

The **MICRA-D** has to be programmed to work under protocol ASCII (Pr1) y (dLY 1). See Page 49

Example ticket without date using printer

#01
NET: +1234.5

Example ticket without date using printer

#01
NET: +1234.5

Time 15:07 Date 11/04/05

If the selected function is number 13 and any of the 2RE, 4RE, 4OP, 4OPP options is installed, the user will have to choose one of the two or four setpoints available depending on the option, which will be the value displayed by the instrument when this function is activated.

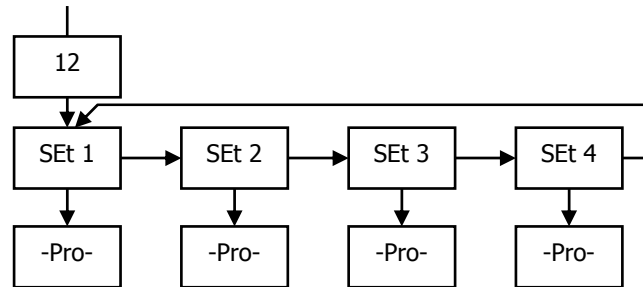

7. PROGRAM PARAMETERS AND KEYBOARD FUNCTIONS LOCK-OUT

The instrument is supplied with all software programming parameters accessible to operator's modifications. After completing the software configuration, it is recommended to protect configuration settings by the following steps:

1. Lockout programming parameters to prevent from accidental or unauthorized modifications.
2. Lockout keyboard functions to prevent from accidental or unauthorized modifications.
3. There are two modes to lock-out the program parameters; total or selective. If some parts of the program have to be adjusted at a later time, make a selective lock. If you don't need to make changes, make a total lock.
4. The access to the lockout routine is allowed by entering a safety code. At factory this code is set to **0000**. We recommend changing this code, to write it down and keep in a safe place.

TOTAL LOCKOUT

The access to the programming routines to read data is allowed even if all parameters are locked out totLC=1, but **it will not be possible to enter or modify data**. In this case, when entering in the programming mode, the display shows the indication "-dAtA-".

SELECTIVE LOCKOUT

When only some parameters are locked out, all configuration data can be read but **only non-protected parameters can be modified**. In such case, when entering in the programming mode, the display shows the indication -Pro-.

Menus or submenus that can be locked out are:

- Setpoint 1 configuration (SEt 1).
- Setpoint 2 configuration (SEt 2).
- Setpoint 3 configuration (SEt 3).
- Setpoint 4 configuration (SEt 4).
- Input configuration (InPut).
- Display (dsp)
- Analog output configuration (Anout).
- Serial output configuration (rSout).
- Logic inputs configuration (LoGIn).
- Lock-out of the reset key, not of the logic function.
- Offset value configuration
- Direct access to the Setpoints value configuration (SEtVAL).

The first four and "SEtVAL" only appear if the corresponding option 2RE, 4RE, 4OP ó 4OPP has been installed, "Anout" will appear when any of the NMA or NMV options are installed, and "rSout" when any of the RS2 or RS4 options are installed.

7.1 – Security menu diagram

The following figure shows the security menu. In this menu is configured the programming lockout. The access to this menu is accomplished from the run mode by pressing the  key during 3 seconds, until the "CodE" indication appears.

The instrument is shipped from factory with the following default code: "0000". Once entered this code, the "LIST" indication will appear, from which we will enter in the parameters lockout. Acceding to the "CHAnG" menu will allow us to enter a personal code, that we have to write down and keep in a safe place (**Do not count on your memory**). This personal code makes the default code useless.

If an incorrect code is entered, the instrument will return automatically to the run mode.

Total lockout programming is achieved changing to 1 the "totLC" variable, changing it to 0, will lead to the selective lockout of the programming variables. Programming each one of the parameters to 1 will activate the lockout, if they are set to 0 programming will be accessible. Though the programming is locked out, it remains possible to visualise the current programming.

The "StorE" indication informs that the modifications effectuated have been stored correctly.

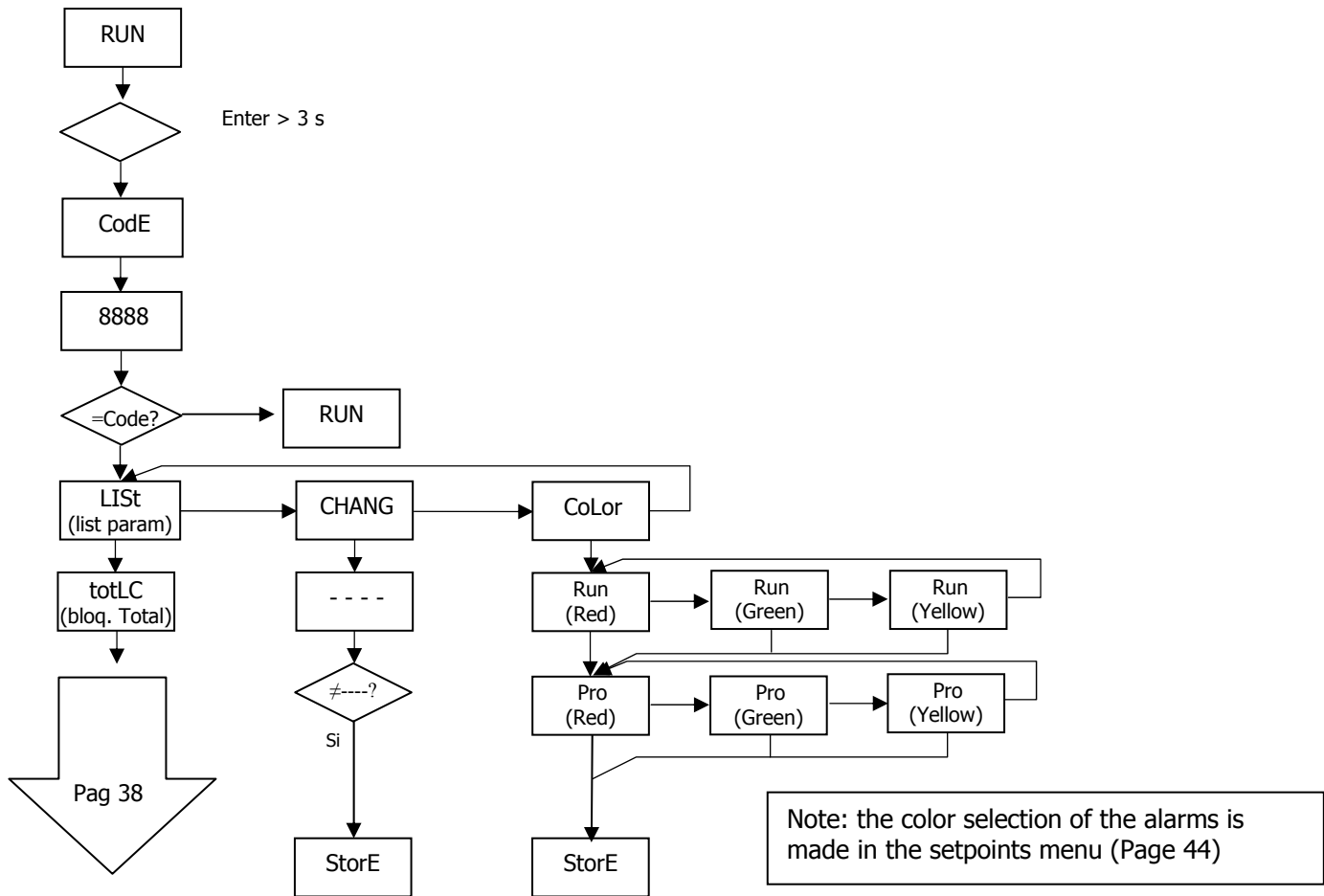

Note: the color selection of the alarms is made in the setpoints menu (Page 44)

8. RESTORATION OF FACTORY CONFIGURATION

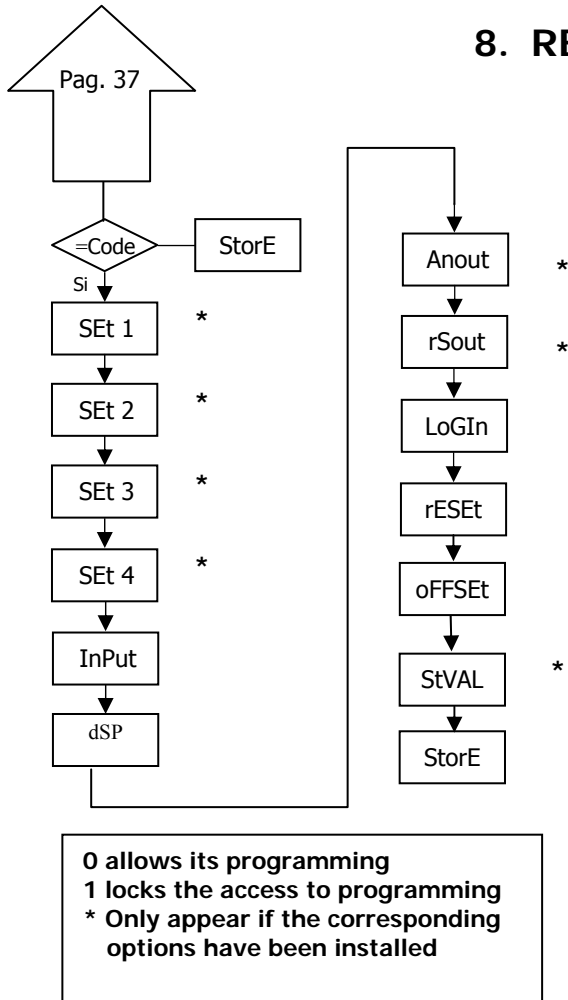

Following the herewith diagram, factory configuration can be restored:

CnInP = - 6- , Encoder /TTL, Count, uP-do, PHASE.

CndSP = ProC without decimal; offset=0, multiplying factor= 1, without decimal;
 Tot YES, without decimal, multiplying factor= 1, without decimal ;

Setpoint 1= on, ProC=1000, mode=1, latch, alarm= red,
 Tot=1000, mode=1, latch, alarm= red,

Setpoint 2, 3, 4 same as Sepoint 1 but setpoint value to 2000, 3000 and 4000.

Anout = outHI= 1000, outLo=0000

rSout = Baud 9600, Adr= 01, trans= Prt 2

LoGIn = InP-1=1, InP-2=2, InP-3=6

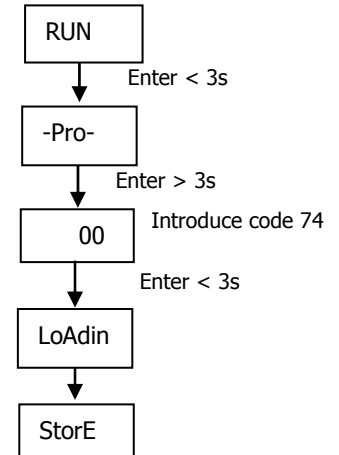

9. OUTPUT OPTIONS

Optionally, model MICRA-D can incorporate one or several output options for control or communication:

Communication options

RS2	Serial RS232C
RS4	Serial RS485

Control options

NMA	Analog 4-20 mA
NMV	Analog 0-10 V
2RE	2 Relays SPDT 8 A
4RE	4 Relays SPST 5 A
4OP	4 NPN outputs
4OPP	4 PNP outputs

All mentioned options are optoisolated with respect to input signal and power supply.

The output cards are easily installed on the meter's main board by means of plug-in connectors and each one activates its own programming modules that provides complete software configuration.

Additional capabilities of the unit with output options:

- Control and processing of limit values via ON/OFF logic outputs or proportional output (4-20mA, 0-10V).
- Communication, data transmission and remote programming via serial interface.

For more detailed information on characteristics and mounting, please refer to the specific manual supplied with each option.

The following figure shows the location of the different outputs options.

The **2RE**, **4RE**, **4OP** y **4OPP** options are alternative and only one of them can be placed into the connector M1.

The **RS2** and **RS4** options are also alternative and only one of them can be placed into the connector M2

The **NMA** or **NMV** option is placed into the connector M3.

Up to three output options can be present at the same time and operate simultaneously:

- One analog (ref. **NMA** or ref **NMV**)
- One RS232C (ref. **RS2**) or RS485 (ref. **RS4**).
- One 2 relays (ref. **2RE**) or 4 relays (ref. **4RE**) or 4 NPN (ref. **4OP**) or 4 PNP (ref. **4OPP**) outputs.

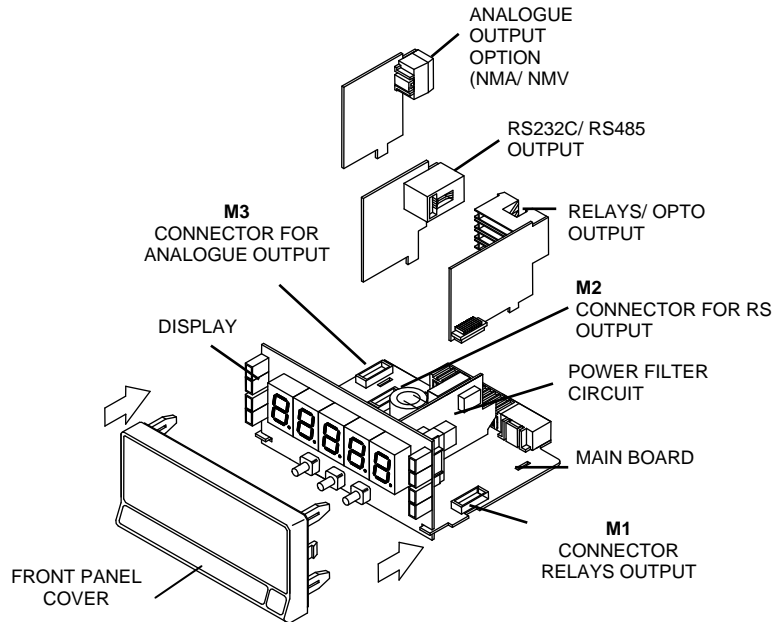

9.1 – Setpoints output

9.1.1 – Introduction

An option of 2 or 4 SETPOINTS, programmable within the full display range, can be incorporated to the unit thus providing alarm and control capabilities by means of individual LED indicators and relay or transistor outputs. All the setpoints provide independently programmable value, time delay (in seconds), asymmetrical hysteresis (in counts of display) and selectable HI/LO acting.

The setpoint option consists of a plug-in additional card that once installed to the meter's main board, activates its own programming module, they are totally configurable by the user and their access can be locked out via software.

These are the control output options available:

2RE: 2 Relays SPDT 8 A

4RE: 4 Relays SPST 5 A

4OP: 4 NPN outputs

4OPP: 4 PNP outputs

These types of outputs, capable of carrying out a wide variety of control operations and processing of limit values, increases notably the unit's performance qualities thanks to the possibility of combining basic alarm functions with advanced safety and control applications.

9.1.2 – Installation

Lift out the electronics assembly from the case and use a screw-driver to push on the junctions between the case and the shadow areas to detach them from the case. See fig. The so performed orifice will allow any of the setpoints (2RE, 4RE, 4OP or 4OPP) board output connectors be brought out at the rear of the instrument. The option is installed by plugging the connector in the main board location. Insert the card pin in the corresponding main board slot and push down to attach both connectors.

If the instrument is to be installed in high vibrating environments, it is recommended to solder the card to the main board making use of the copper tracks on both sides of the card pin and around the main board hole on its solder side.

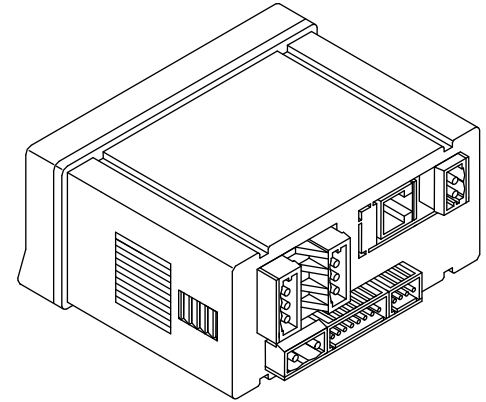

9.1.3 – Wiring

2RE - 2 RELAYS OPTION

PIN 4 = NO2 PIN 1 = NO1
 PIN 5 = COMM2 PIN 2 = COMM1
 PIN 6 = NC2 PIN 3 = NC1

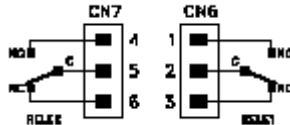

4OP - OPTION 4 OPTOS NPN

PIN 4 = OP4 PIN 1 = OP1
 PIN 5 = N/C PIN 2 = OP2
 PIN 6 = COMM PIN 3 = OP3

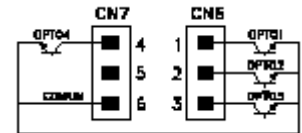

4RE - 4 RELAYS OPTION

PIN 4 = RL4 PIN 1 = RL1
 PIN 5 = N/C PIN 2 = RL2
 PIN 6 = COMM PIN 3 = RL3

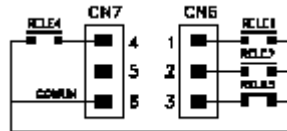

4OPP – OPTION 4 OPTOS PNP

PIN 4 = OP4 PIN 1 = OP1
 PIN 5 = N/C PIN 2 = OP2
 PIN 6 = COMM PIN 3 = OP3

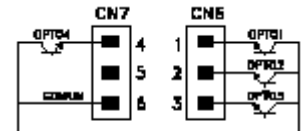

Each output card is supplied with an adhesive label that indicates the wiring connections of each option. To help identifying each terminal, this label should be placed in the lower side of the meter case, beside the basic functions label.

NOTE: In case that the outputs are used to drive inductive loads, it is recommended to add an RC network between the coil terminals (preferably) or between the relay contacts to limit electromagnetic effects.

9.1.4 – technical specifications

CHARACTERISTICS	2RE OPTION	4RE OPTION
MAX.CURRENT(RESISTIVE LOAD).....	8 A	5 A
MAX.POWER.....	2000 VA / 192 W	1250 VA / 150 W
MAX.VOLTAGE.....	250 VAC / 150 VDC	277 VAC / 125 VDC
CONTACT RESISTANCE	Max. 3mΩ	Max. 30mΩ
SWITCHING TIME.....	Max. 10ms	Máx. 10ms

4OP and 4OPP OPTION

MAX VOLTAGE.....	50 VDC
MAX CURRENT	50 mA
LEAKAGE CURRENT	100 μA (max.)
SWITCHING TIME.....	1 ms (max.)

9.1.5 - Setpoints menu diagram in mode Frequency / Tachometer

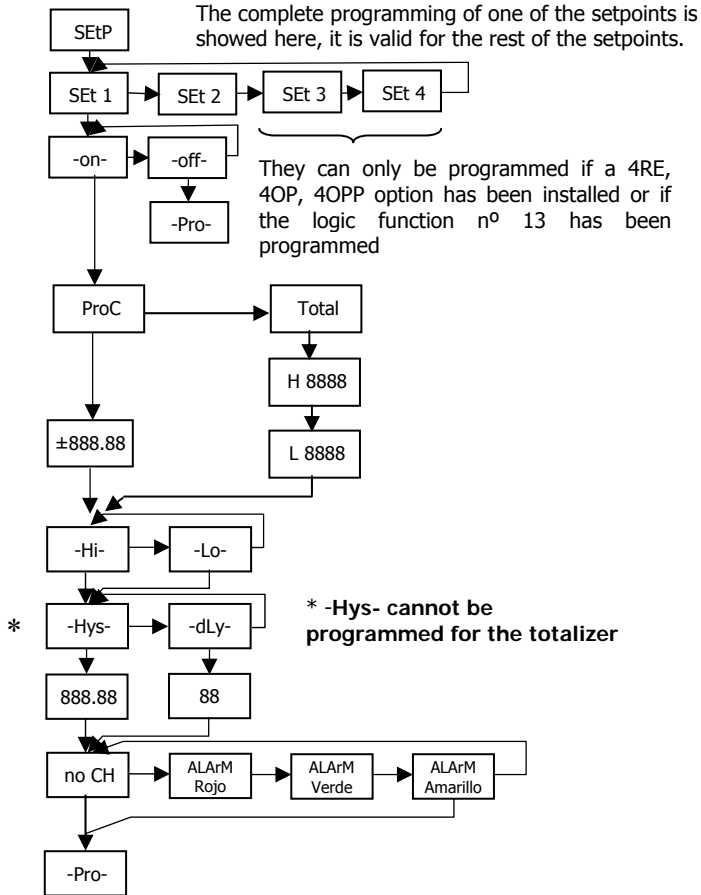

9.1.6 – Direct access to the setpoints value programming

If any of the options corresponding to the setpoints has been installed, it is possible to accede directly to the setpoints value without need to go through the programming menu just by pressing the  key in PROG mode, as showed in diagram below, supposing that the card installed are 4RE, 4OP or 4OPP, if it is the 2RE card only Set1 y Set2 would appear.

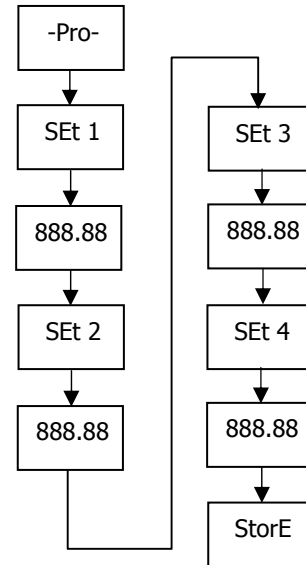

Remember that the decimal point position comes determined by what has been programmed in the SCAL menu.

9.1.7 – Description of operation in Frequency Meter, Tachometer mode.

As programmed like independent setpoints, the alarm outputs activate when the display value reaches the user-programmed value. The independent alarms programming requires definition of the following basic parameters:

b. HI/ LO ACTING MODE.

In HI mode, the output activates when the display value exceeds the setpoint level and in LO mode, the output activates when the display value falls below the setpoint

c. PROGRAMMABLE TIME DELAY or HYSTERESIS.

Each output action can be deferred by a programmable time delay or hysteresis level.

The time delay is the time that takes the output to activate after passing through the setpoint in the up or down direction, while the hysteresis band will be selected asymmetrical i.e. only acts on the output deactivation edge.

The delay is programmable in seconds, from 0 to 99.

The hysteresis can be programmed, in counts, within the full display range. The decimal point appears in the same position as programmed in the display configuration module.

The figures 1 and 2 show the time delay action (dly) and the asymmetrical hysteresis action (hys-1) of two alarms (SET1 and SET2) programmed to activate in HI mode (OUT1) and LO mode (OUT2)

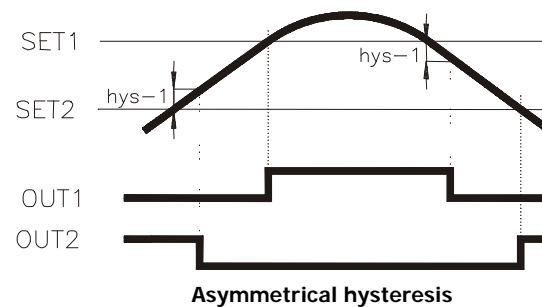
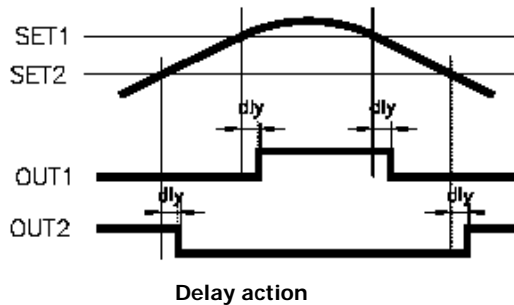

9.1. 8 – Diagram of the menu of Setpoints in mode Counter / Chronometer

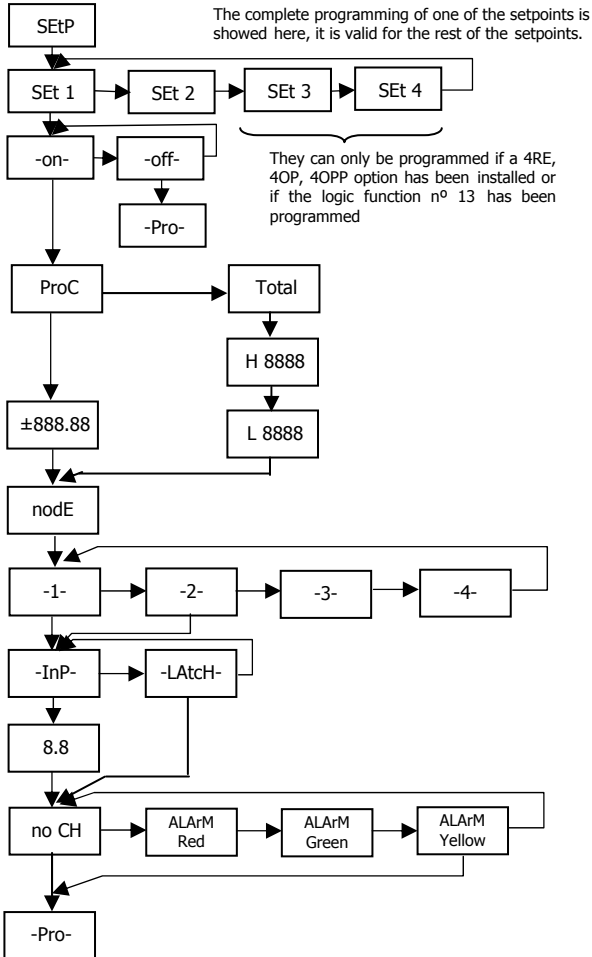

9.1.9 - Description of Mode "relays operating as Counter/Chronometer"

Mode 1 No function. When configured as Process or total counter, enables the output (pulse or latch), whether it comes from a lower or higher value than the programmed value.

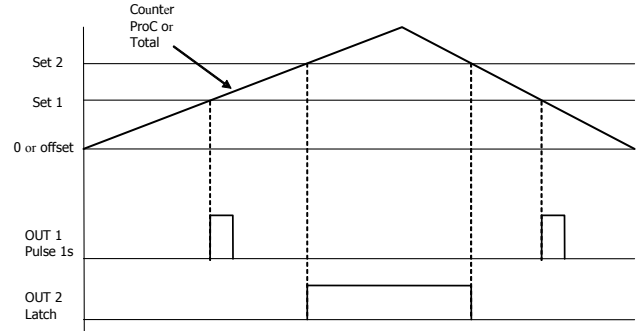

Mode 2 Reset

The value of the variable to which the setpoint is related is reset to zero (or to the offset value) when enabling output. In this mode the output **cannot be programmed as Latch**.

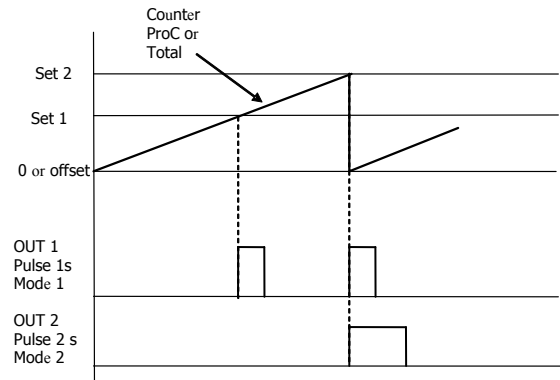

Mode 3 Stop

All process, batch and total counters, where applicable, will

Mode 3 Stop

All process, batch and total counters, where applicable, will stop during the output enabling time. Where the output is pulse, the counters will restart once the enabling time is complete. If the output is latch, the counters will restart when the counter to which the setpoint is related is reset.

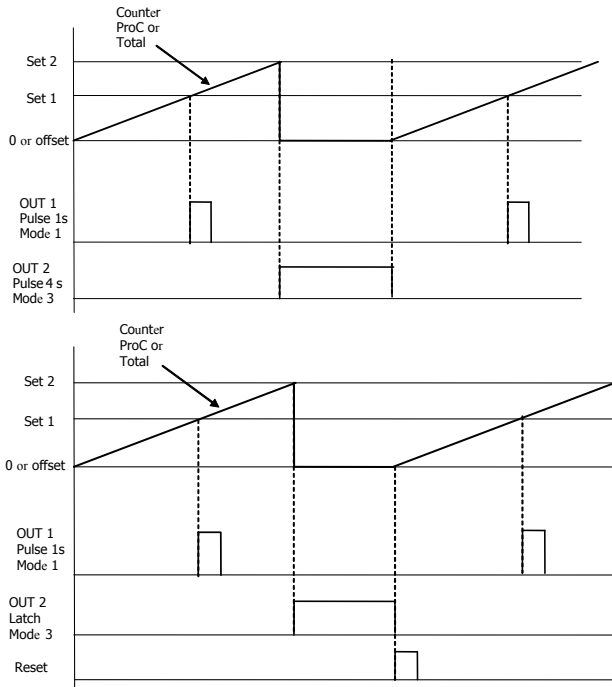

Mode 4 Clear

On enabling the output, the previous setpoint output is disabled, if it had been enabled.

(The setpoint prior to 1 is 4)

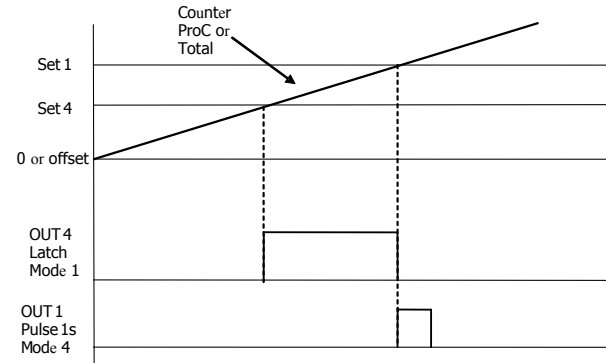

9.2 – RS2 / RS4 Output

9.2.1 – Introduction

The RS232C output option consists of an additional card (reference **RS2**) that is installed in the M2 plug-in connector of the instrument's main board. The card incorporates one 4 wires telephone socket with output at the rear of the instrument.

The RS485 output option consists of an additional card (reference **RS4**) that is also installed in the M2 plug-in connector of the instrument's main board. The card incorporates a 6-pin / 4-contact telephone socket with output at the rear of the instrument.

The serial output permits to construct a communication line through which a master device can request the transmission of data such as display value, setpoint values, peak, valley, tare (or offset in case of thermometers) and to perform operations such as tare of the display, reset of the peak, valley or tare memories and update setpoint values..

The output option is totally software configurable as for the transmission rate (1200, 2400, 4800, 9600 or 19200 Baud), the instrument's address (from 00 to 99), the protocol (ASCII, ISO 1745 and MODBUS RTU).

The operating mode is half-duplex and it normally stands in data reception mode until reception of a message.

A valid data transmission may cause the immediate execution of an action (tare, reset of peak, valley or tare memories modification of setpoint values) or the transmission of a response from the instrument (display value, one of the setpoints value, peak, valley, tare / offset). Only the display value can be called up via external contact according diagram in page 9 of RS2 manual.

Three communication modes are available; the ASCII mode uses a simple protocol compatible with several DITEL instruments. The ISO mode, in accordance with the ISO 1745 norm, allows a more effective communication in noisy environments as it checks the messages validity checking both transmission and reception. And eventually the protocol MODBUS RTU

As you will see in the functions table, the protocol ASCII uses 1 or 2 bytes according to the command type and the protocol ISO 1745 imposes the use of two bytes per command.

9.2. 2 – Diagram of the menu Input RS

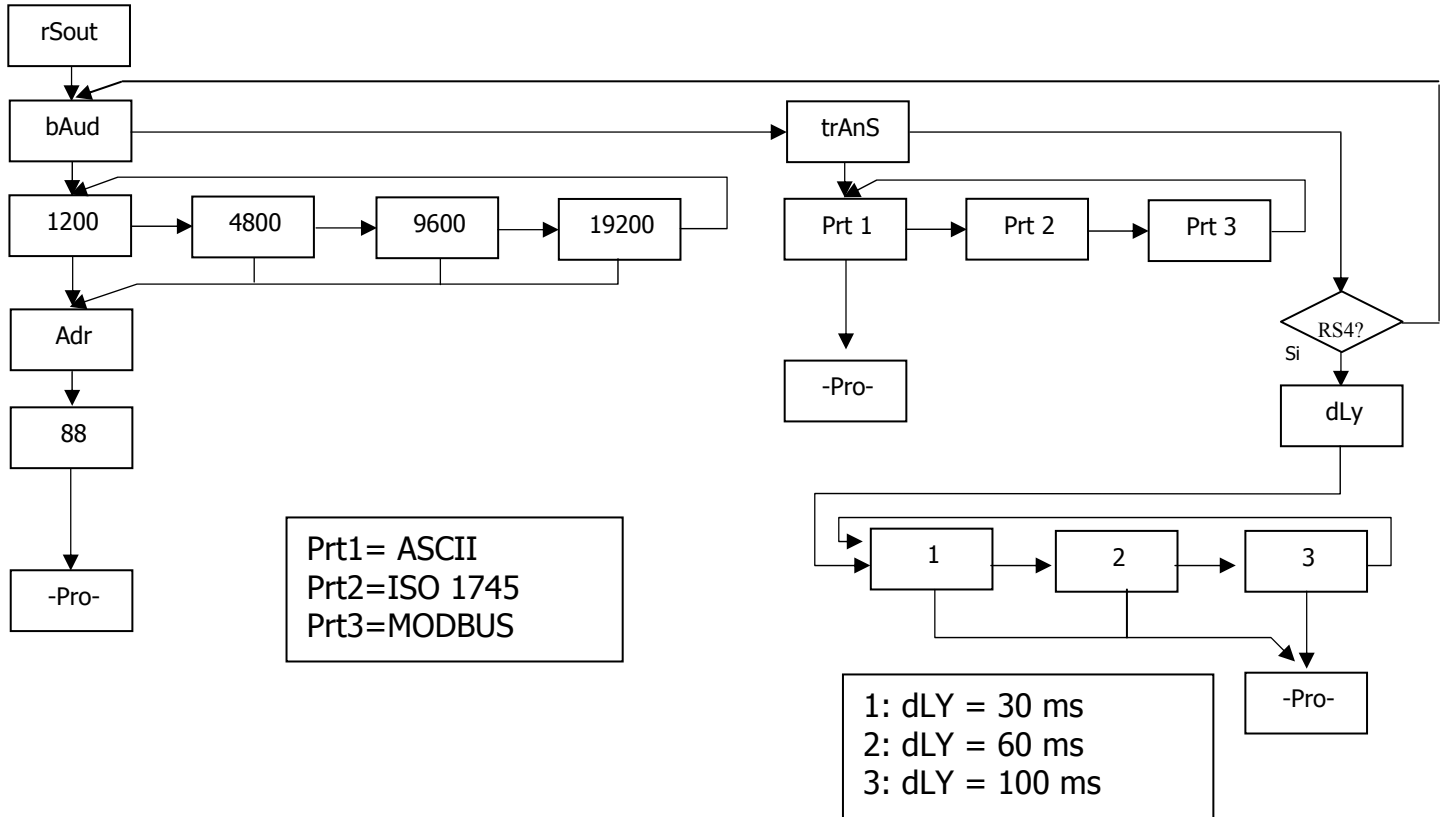

ASCII PROTOCOL

The Transmission format is: 1 START bit, 8 DATA bits, NO parity bit and 1 STOP bit.

- MESSAGE FORMAT TO BE SENT

A message sent to the instrument must be composed of the following sequence of ASCII characters:

*	D	d	C	C	X	X	CR
---	---	---	---	---	---------	---	----

One " * " byte [ASCII 42] of start of message.

Two address bytes (from 00 to 99).

One or two ASCII characters corresponding to the desired command according to the functions table (List of commands).

In case that the command request for a modification of parameters, the new value shall be transmitted with one byte of sign (+ [ASCII 43] or - [ASCII 45]) followed by a block of N ASCII characters (depending on model), including the decimal point.

One " CR " [ASCII 13] character of end of message. CR= Carriage Return

- MESSAGE FORMAT FROM INSTRUMENT

The data sent from the instrument as a response to a data request type command from the master device is the following:

SP	X	X	CR
----	---------	---	----

One byte of blank space [ASCII 32].

One text (requested values) consisting of a byte of sign (+ [ASCII 43] or - [ASCII 45]) followed by a block of N ASCII characters (depending on model) including the decimal point.

One " CR " byte [ASCII 13] of end of message. CR = Carriage Return

If the command belongs to "orders" or "changing parameters", the instruments gives no response.

ISO 1745 PROTOCOL

The transmission format is: 1 START bit, 7 DATA bits, 1 EVEN PARITY bit and 1 STOP bit.

• MESSAGE FORMAT TO BE SENT

The message format, as sent from the master device, must consist of the following sequence of characters:

SOH	D	d	STX	C	C	X X	ETX	BCC
-----	---	---	-----	---	---	-----------	-----	-----

One byte SOH of start of message [ASCII 01].

Two bytes corresponding the first to the tens and the second to the units of the instrument address number.

One byte STX of start of text [ASCII 02].

Two commands bytes according to the functions table.

In case of commands that change parameters, a block of N bytes corresponding to the new value including sign and decimal point.

One byte ETX of end of text [ASCII 03].

One control byte BCC calculated in the following manner:

Perform an exclusive-OR with all bytes between the STX (not included) and the ETX (included).

- If the obtained byte (in ASCII format) is higher than 32, it can be taken as the BCC.

- If the obtained byte (in ASCII format) is lower than 32, the BCC byte will be obtained by adding 32.

• MESSAGE FORMAT FROM INSTRUMENT

The format of a message as sent from the instrument in response to a command from the master device is the following:

1. In case of commands that ask for transmission of a value (data request type):

SOH	D	d	STX	X	X	ETX	BCC
-----	---	---	-----	---------	---	-----	-----

One byte SOH of start of message [ASCII 01].

Two address bytes.

One byte STX of start of text [ASCII 02].

N bytes corresponding to the requested value (including the sign and decimal point).

One byte ETX of end of text [ASCII 03].

One control byte BCC calculated with the method described in above.

2. In case of commands that do not imply the return of a value (command type or changing parameter):

D	d	ACK	or	D	d	NAK
---	---	-----	----	---	---	-----

The instrument sends a confirmation when it receives a message.

If the message has been correctly received and interpreted, the response will consist of two address bytes and one "ACK" [ASCII 06]

If the received message has not been well interpreted or it has been detected as to have errors, the response will be two address bytes and a "NAK" [ASCII 21].

List of commands

PETICIÓN DE DATOS

ASCII	ISO	Information
P	0P	Peak value
V	0V	Valley value
T	0T	Tare or offset value
D	0D	Display value
L1	L1	Setpoint 1 value
L2	L2	Setpoint 2 value
L3	L3	Setpoint 3 value
L4	L4	Setpoint 4 value
	NB	Cards installed
		Returns:
		- "04": RS2
		- "05": RS2, 2RE
		- "06": RS2, 4OP
		- "08": RS4
		- "09": RS4, 2RE
		- "0": RS4, 4 Setpoints(4RE, 4OP or 4OPP)
		- "44": NMA or NMV, RS2
		- "45": NMA or NMV, RS2, 2RE
		- "46": NMA or NMV, RS2, 4 Setpoints(4RE, 4OP or 4OPP)
		- "48": NMA or NMV, RS4
		- "49": NMA or NMV, RS4, 2RE
		- "4": NMA or NMV, RS4, 4 Setpoints(4RE, 4OP or 4OPP)
TT		Model + Version

MODIFICATION OF DATA

ASCII	ISO	Parameter
M1	M1	Change the setpoint1 value in memory
M2	M2	Change the setpoint2 value in memory
M3	M3	Change the setpoint3 value in memory
M4	M4	Change the setpoint4 value in memory

COMMANDS

ASCII	ISO	Command
p	0p	Peak reset
v	0v	Valley reset
r	0r	Tare reset

9.3 ANALOG OUTPUT

9.3.1 – Introduction

Two ranges of analog output (0-10 V and 4-20 mA) can be incorporated to the MICRA D by means of an additional card, either the NMV card for voltage output or the NMA card for current output, which is installed on the meter's main board via plug-in connector M3, both cards, cannot be used simultaneously.

The outputs are opto-isolated with respect to the signal input and the power supply.

The optional board provides a two terminal connector [(+) and (-)] that drives out a signal variation from 0 to 10V or from 4mA to 20mA proportional to a user-defined display range.

This way, the meter is furnished with a signal that can be used to control variables and operates at each moment proportionally to the magnitude of the effect under control.

These signals can also be used to transmit display information to a variety of terminal equipment such as graphic recorders, controllers, remote displays or other devices that accept input data in analog form.

The instrument will detect the type of option that has been installed and will operate in accordance.

The display values producing the full scale output (OUT-HI and OUT-LO) are also introduced via front-panel buttons in the same programming module. The analog output then follows the display variation between the HI and LO programmed points.

The output signal can be set up for reverse action by programming the low display for the high output (OUT-HI) and the high display for the low output (OUT-LO).

9.3.2 – Installation of NMA or NMV option

Lift out the electronics assembly from the case and use a screwdriver to pull on the junctions between the case and the grey-marked area to detach it from the case. The so performed orifice will allow the analog output board connector be brought out at the rear of the instrument. Install the circuit board so that the lower pin fits into the corresponding main board insertion slot and push down to plug the M3 option connector in the main board M3 location. If the instrument is to be installed in high vibrating environments, it is recommended to solder the card to the main board making use of the copper tracks on both sides of the card pin and around the main board hole on its solder side.

9.3.3 – Connection

Each output card is supplied with an adhesive label that indicates the wiring connections of each option (see fig.). To help identifying each terminal, this label should be placed in the side of the meter case, beside the basic functions label.

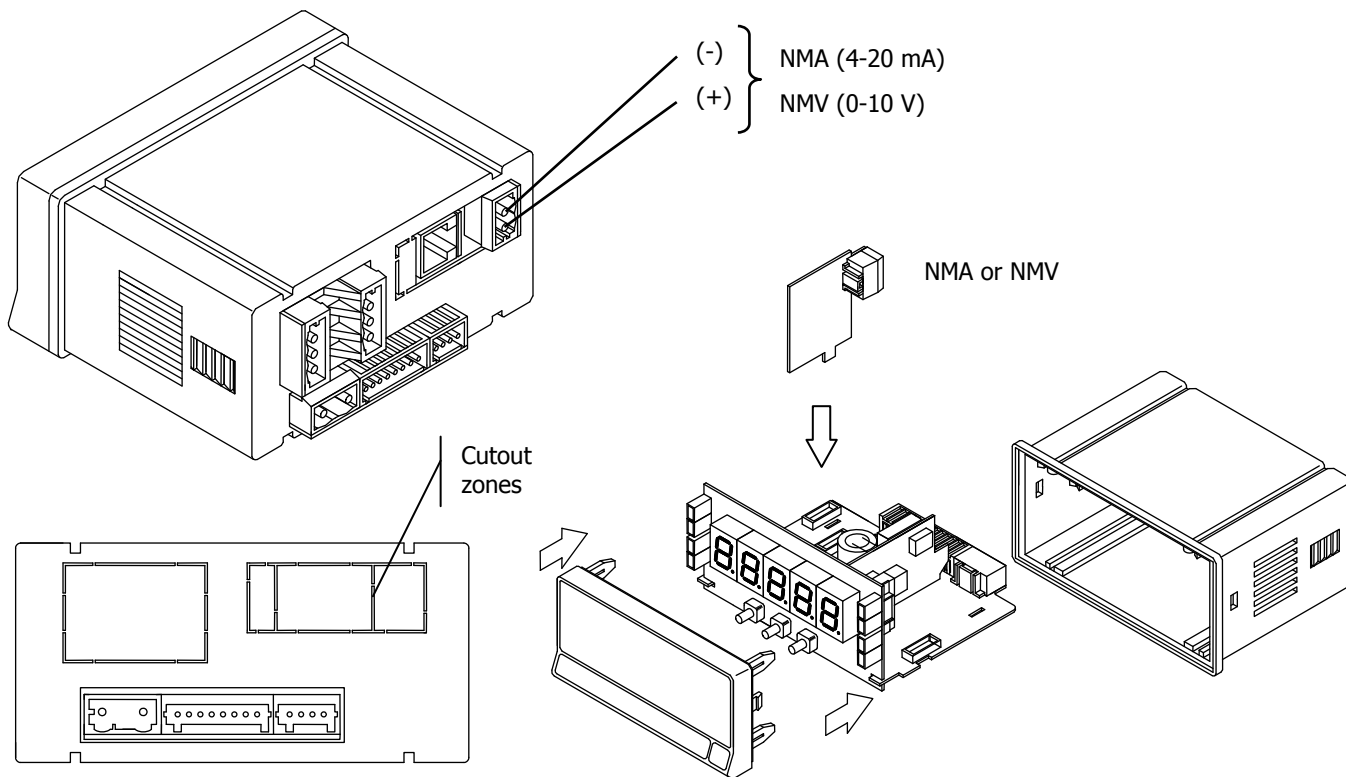

9.3.4 – Technical specifications

CHARACTERISTICS	NMA OUTPUT	NMV OUTPUT
RESOLUTION	13 BITS.....	13 BITS.....
ACCURACY	0.1% F.S. ±1BIT	0.1% F.S. ±1BIT
RESPONSE TIME.....	50 ms.....	50 ms.....
THERMAL DRIFT	0.5 μ A/ $^{\circ}$ C.....	0.2 mV/ $^{\circ}$ C.....
MAXIMUM LOAD.....	\leq 500 Ω	\geq 10 K Ω

9.3.5 - Analog output menu diagram

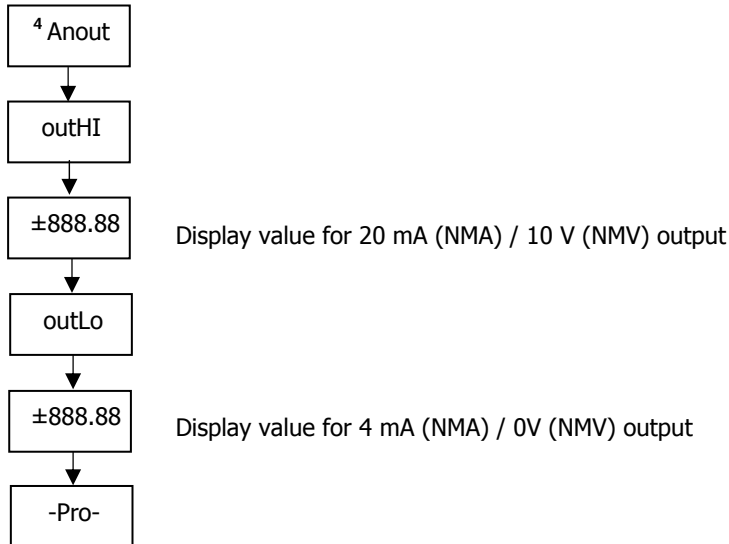

INPUT SIGNAL

Frequency meter and Tachometer

Frequency Limits

MIN frequency0.01Hz
MAX frequency without totalizer 40 KHz
MAX frequency with totalizer 10 KHz

Counter

MAX count rate (*)

Up or down without relays 20 KHz
Up or down with relays 15 KHz
Bidirectionnal Phase or Direc without relays ... 20 KHz
Bidirectionnal phase or Direc with relays 15 KHz
Bidirectionnal Indep without relays 20 KHz
Bidirectionnal Indep with relays 15 KHz

EXCITATION 8V/24V DC @ 30mA
18Vdc (not stabilized) @ 100 mA

Contact closure

FILTER

Fc with duty cycle 50% 20Hz
Fc with duty cycle 30% 10Hz

INPUTS (2 CHANNELS)

MAGNETIC PICKUP

Sensitivity $V_{in} (AC) > 60mV_{pp} @ F < 1kHz$
..... $> 120 mV_{pp} @ F < 1 kHz$

NAMUR

Rc 3k3 (incorporated)
Ion $< 1mA DC$
Ioff $> 3mA DC$

TTL/24V DC (encoder)

Logic levels "0" $< 2.4V DC$, "1" $> 2.6V DC$

NPN or PNP

Rc 3K3 (incorporated)
Logic levels "0" $< 2.4V DC$, "1" $> 2.6V DC$

CONTACT CLOSURE

Vc 5V
Rc 3.9K
Fc (programmable) 20Hz

HIGH VOLTAGE INPUT (1 CHANNEL)

Voltage limits 10 to 300V AC

COUNTER Y CHRONOMETER MEMORY

Non-volatile E2PROM retains all programming data and count value when power is removed or interrupted.

DISPLAY

Type..... 5 programmable tricolor 14 mm digits
LED's..... 8, control and status indication
Decimal Point..... programmable
Sign..... automatic s/configuration
Positive overflow indication OvEr
Negative overflow indication -OvEr

Counter display limits Process -99999 to 99999

Totalizer -99999999 to 99999999
Chronometer ranges..... 4, from 999.99s to 9999.9h
Frequency ranges.... 0.01 Hz to 40KHz/10KHz(totalizer)
Tachometer range 0 to 99999(rpm), programmable (rate)
Scale factor
Counter programmable from 0.0001 to 99999
Freq/Tach..... programmable from 0.0001 to 99999

Display update rate

Counter 100ms
Chronometer..... 100ms
Frequency/Tachometer programmable 0.1 to 9.9s

POWER

MICRA-D 85 to 265 Vac 50/ 60Hz
..... 100 to 300 V dc
MICRA-D6 10,5-70V DC
..... 22 to 50 V ac 50/ 60 Hz

Consumption 5W (without options), 10W max

ACCURACY

Frequency/Tachometer 0,005%
Chronometer..... 0, 01%
Temperature coefficient 50 ppm/°C
Warm up time 5 minutes

AMBIENT

Indoor use
Operating temp. -10°C to 60°C
Storage temperature..... -25°C to +85°C
Relative humidity (non condensing) < 95% at 40°C
Max altitude 2000m

MECHANICAL

Dimensions..... 96x48x60mm (DIN 43700)
Panel cutout 92x45mm
Weight 200g
Case material Polycarbonate (UL 94 V-0)
Sealed front panel..... IP65

DECLARATION OF CONFORMITY

Manufacturer: DITEL - Diseños y Tecnología S.A.

Address: Poligono Industrial Les Guixeres
C/ Xarol 8 C
08915 BADALONA
SPAIN

Declares, that the product:

Description: Digital panel meter
multifunction

Model: **MICRA-D**

Conforms with the directives: EMC 89/336/CEE
LVD 73/23/CEE

Date: 08.06.2007

Signed: José M. Edo

Function: Technical manager



EMC

EN 61000-6-2 EN 61000-4-2	Generic immunity Electrostatic discharge Air discharge 8kV Contact discharge 4kV	Criteria B
EN 61000-4-3	Electromagnetic fields RF 10V/m	Criteria A
EN 61000-4-4	Fast transients Power supply Lines 2 kV Signal Lines 1 kV	Criteria B
EN 61000-4-5	Surge 1 kV L/N 2 kV L,N/Ground 1 kV Signal Lines and ground	Criteria B
EN 61000-4-6	RF conducted interferences 10 V rms	Criteria A
EN 61000-4-11	Voltage dips and interruptions 30% reduction 0,5 period	Criteria B
EN 61000-6-3	Generic emission EN 55022/ CISPR22	Criteria A
EN 61010-1	General safety Installation category II Pollution degree 2 Conductive pollution excluded Insulation type Enclosure: Double Inputs/Outputs: Basic	



The instruments are warranted against defective materials and workmanship for a period of three years from date of delivery.

If a product appears to have a defect or fails during the normal use within the warranty period, please contact the distributor from which you purchased the product.

This warranty does not apply to defects resulting from action of the buyer such as mishandling or improper interfacing.

The liability under this warranty shall extend only to the repair of the instrument. No responsibility is assumed by the manufacturer for any damage which may result from its use.



All the DITEL products benefit from an unlimited and unconditional warranty of THREE (3) years from the date of their purchase. Now you can extend this period of warranty up to FIVE (5) years from the product commissioning, only by fulfilling the corresponding form.

Fill up the form in our website at:
<http://www.ditel.es/warranty>



INSTRUCTIONS FOR THE RECYCLING

This electronic instrument is covered by the **2002/96/CE** European Directive so, it is properly marked with the crossed-out wheeled bin symbol that makes reference to the selective collection for electrical and electronic equipment which indicates that at the end of its lifetime, the final user cannot dispose of it as unsorted municipal waste.

In order to protect the environment and in agreement with the European legislation regarding waste of electrical and electronic equipments from products put on the market after 13 August 2005, the user can give it back, without any cost, to the place where it was acquired to proceed to its controlled treatment and recycling.

DISEÑOS Y TECNOLOGIA, S.A.

Polígono Industrial Les Guixeres

C/ Xarol 8 C

08915 BADALONA-SPAIN

Tel: +34 - 93 339 47 58

Fax: +34 - 93 490 31 45

E-mail: dtl@ditel.es

www.ditel.es