

PICA100-F INSTRUCTIONS MANUAL

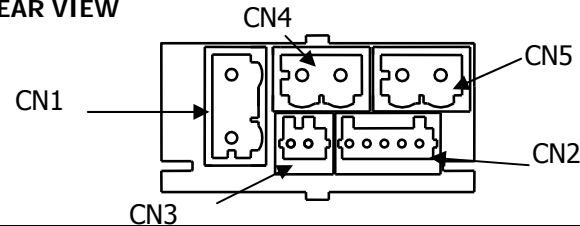

- Panel Instrument for measuring frequencies, velocities in r.p.m. or lineal totally programmable.
- Sensor excitation supply, selectable via programming

REAR VIEW



CONNECTORS DESCRIPTION

CN1 AC SUPPLY
PIN 1 Phase
PIN 2 Neutral

CN1 DC SUPPLY
PIN 1 Negative
PIN 2 Positive

CN3 SALIDA RS485
PIN 1 B = TxD+ / RxD+
PIN 2 A = TxD- / RxD-

CN4 RELAY 1 OUTPUT
PIN 1 } N.O.
PIN 2 }

CN5 RELAY 2 OUTPUT
PIN 1 } N.O.
PIN 2 }

CN2 SIGNAL
PIN 1: 10 to 600 V ac
PIN 2: Not connected
PIN 3: + Input Pulses
PIN 4: - Common
PIN 5: + Excitation (5, 8, 12 V) @ 60 mA

POWER SUPPLY

| | |
|------------|--------------------------|
| PICA100-F | 85 to 265 V AC 50/ 60 Hz |
| PICA100-F6 | 100 to 300 V DC |
| PICA100-F6 | 21 to 53 V AC 50/ 60 Hz |
| PICA100-F6 | 10,5 to 70 V DC |

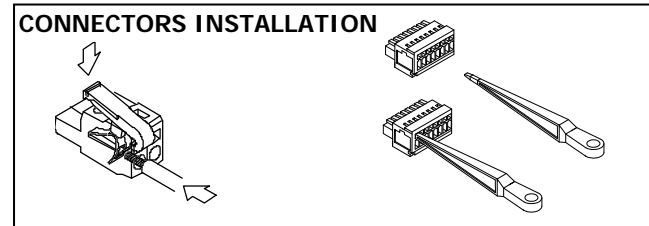

WARNING: If these instructions are not respected, protection against overvoltage is not guaranteed.

In order to guarantee electromagnetic compatibility, the following guidelines for cable wiring must be followed:
Power supply wires must be routed separated from signal wires. Never run power and signal wires in the same conduit.
Use shielded cable for signal wiring and connect the shield to ground.
The cable section must be $\geq 0.25 \text{ mm}^2$

INSTALLATION
To meet the requirements of the directive EN61010-1, where the unit is permanently connected to the mains supply it is obligatory to install a circuit breaking device easy reachable to the operator and clearly marked as the disconnect device.

CLEANING: The frontal cover should be cleaned only with a soft cloth soaked in neutral soap product. **DO NOT USE SOLVENTS**

DESCRIPTION

The PICA100-F, instrument of the KOSMOS Series, size 1/32 DIN with 4 digits LED red 8 mm high.

Its two mounted relays allows this instrument not only to measure but also to control, regulate and detect alarms for the mentioned signals.

Thanks to its communication option RS4P (RS485) it can be integrated within a measurement system and is able to provide information via its MODBUS-RTU protocol.

Tachometer in mode TAC programming only the number of pulses by revolution or in mode Rate programming only the rate Frequency / Display (in desired engineering unit)

Incorporates three keys located on the front bottom for the configuration of all the parameters.

Its brightness level is programmable with 4 levels in order to adapt it to the environment where it works. Registers the minimum and maximum value.

Menu allows total or partial lock-out of programming thanks to a code.

Anti-rebound filter incorporated automatically when programming switch input.

The output options are isolated from the input and the power supply.

WIRING DIAGRAMS ACCORDING INPUT

Input 10 -600V ac

Magnetic pick-up

NPN or PNP Sensor

Switch

Input TTL/24V /Encoder

Namur Sensor

GENERAL PROGRAMMING DIAGRAM

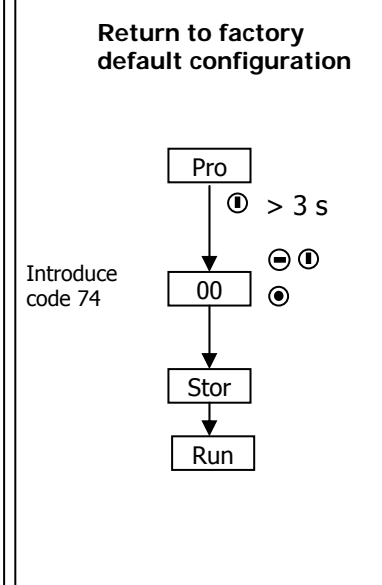
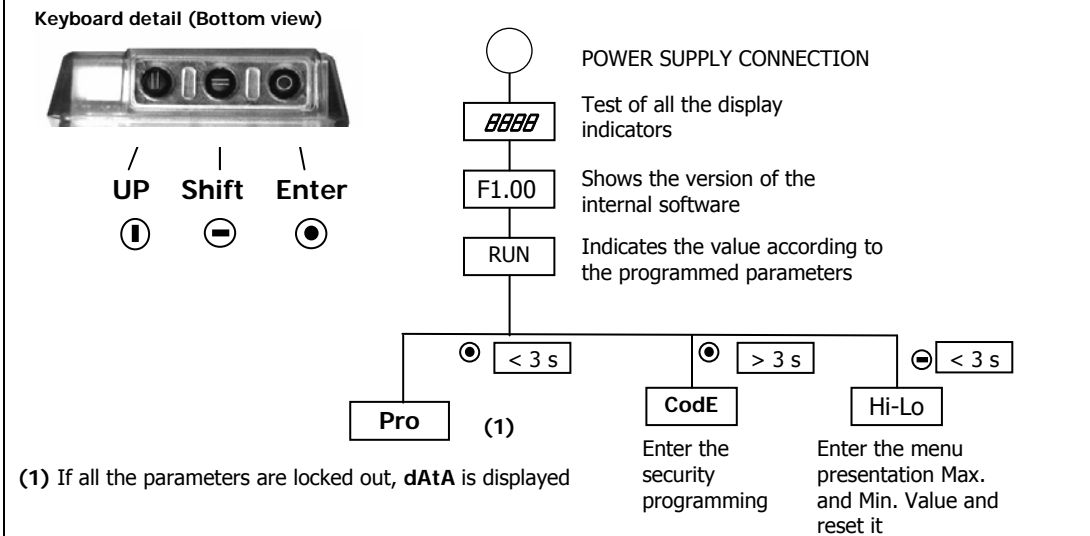

PROGRAMMING MENU DETAILS

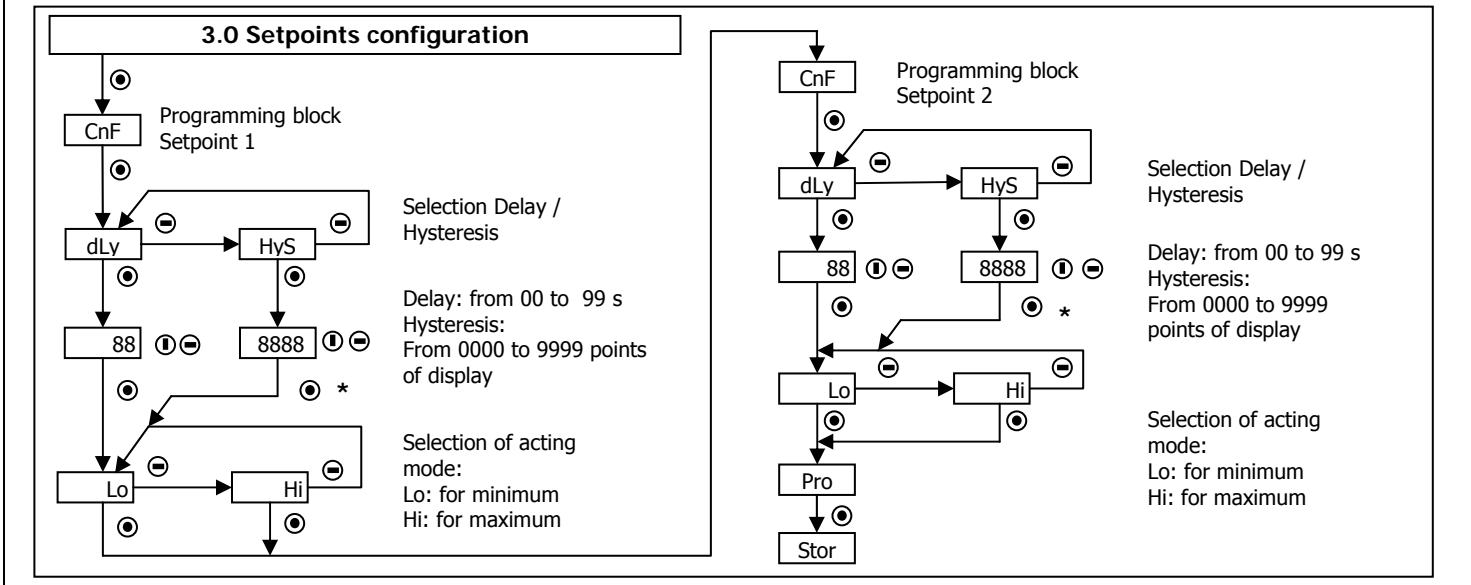
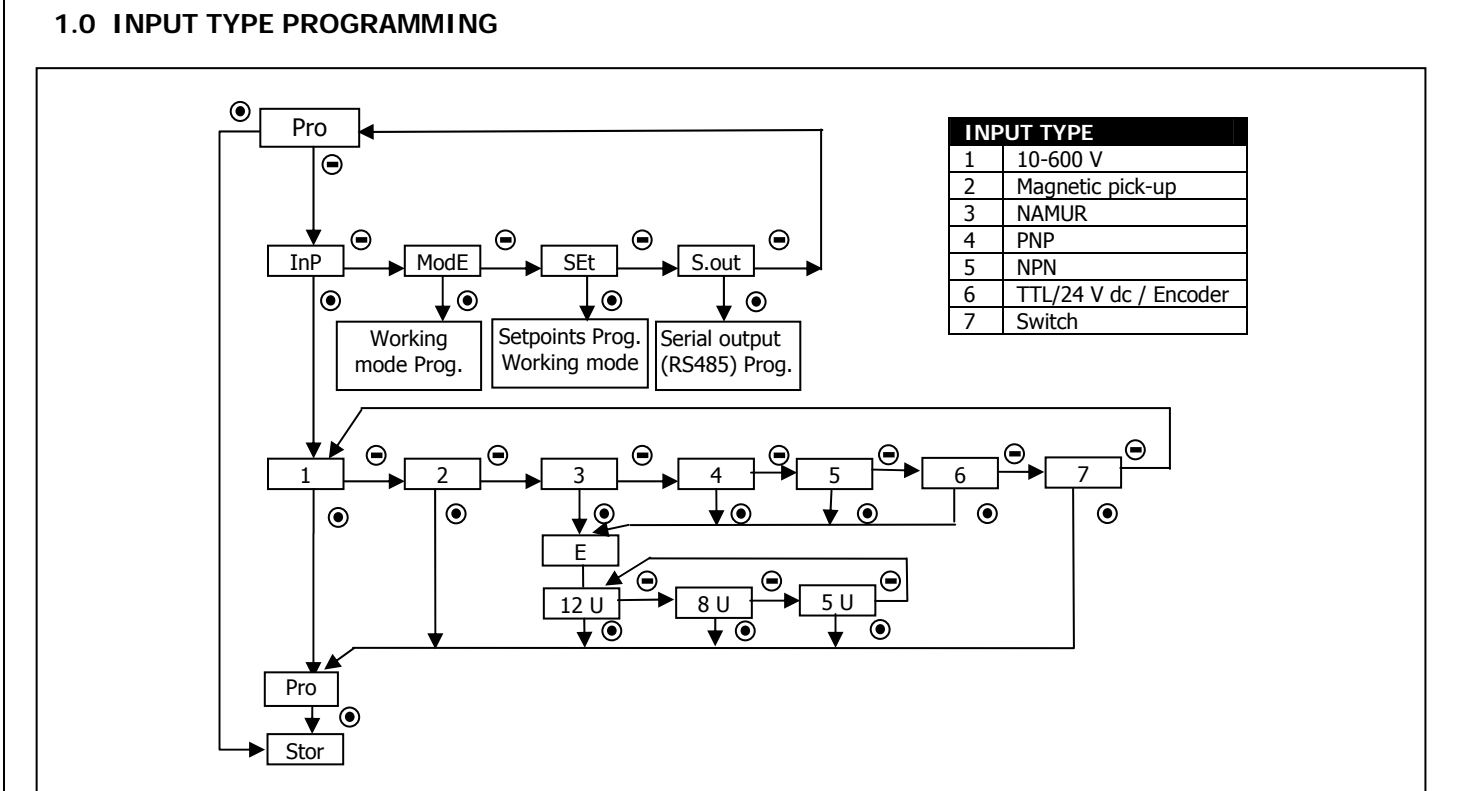

2.1 WORKING MODE PROGRAMMING

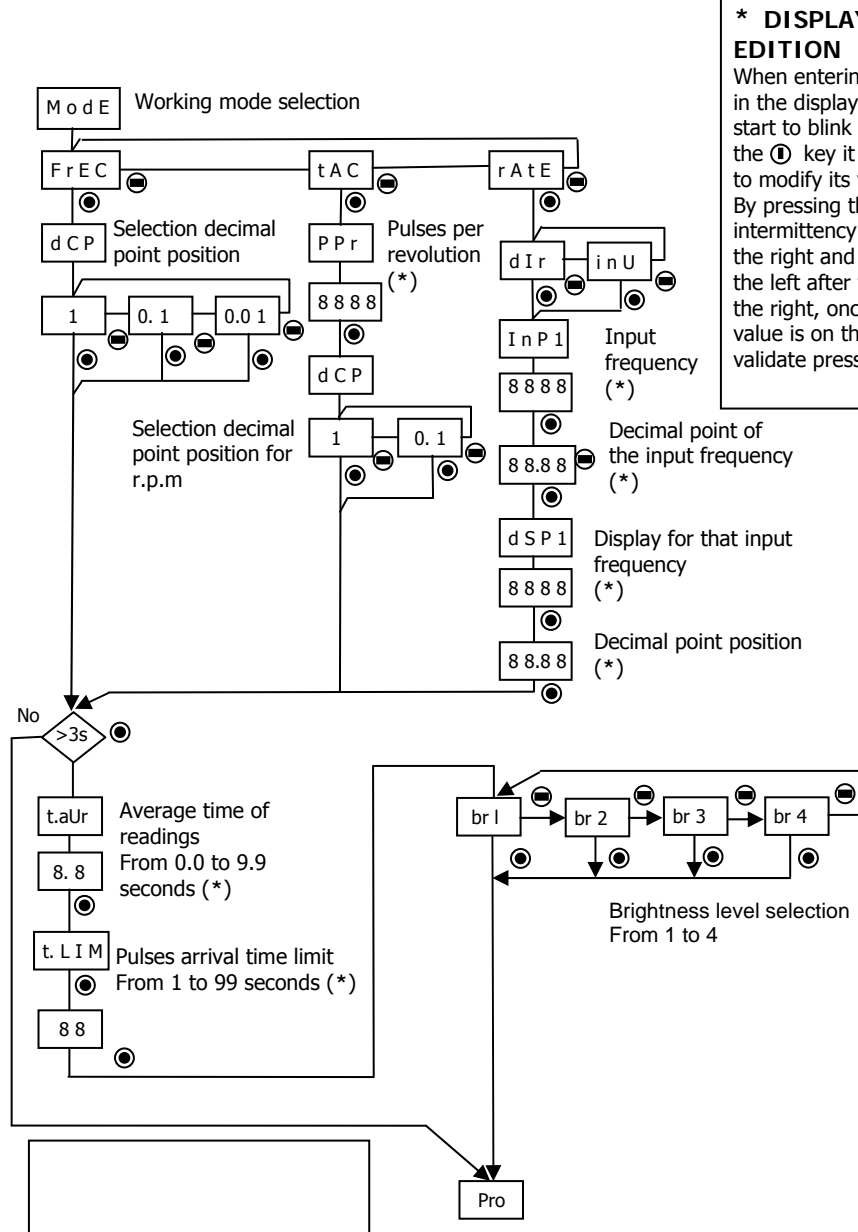

*** DISPLAY VALUE EDITION**
When entering to edit a value in the display the left digit will start to blink and by pressing the **Ⓜ** key it will be possible to modify its value. By pressing the **Ⓜ** key the intermittency will be shifted to the right and will come back to the left after the last digit on the right, once the desired value is on the screen, to validate press on the **Ⓜ** key.

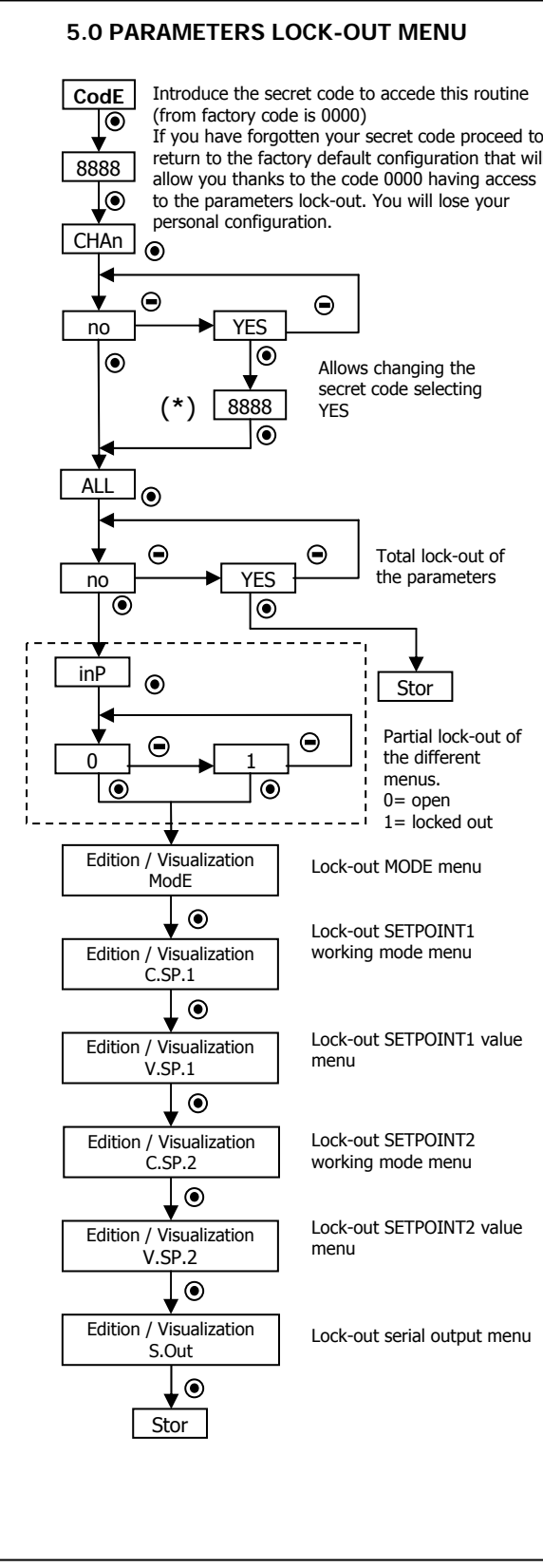
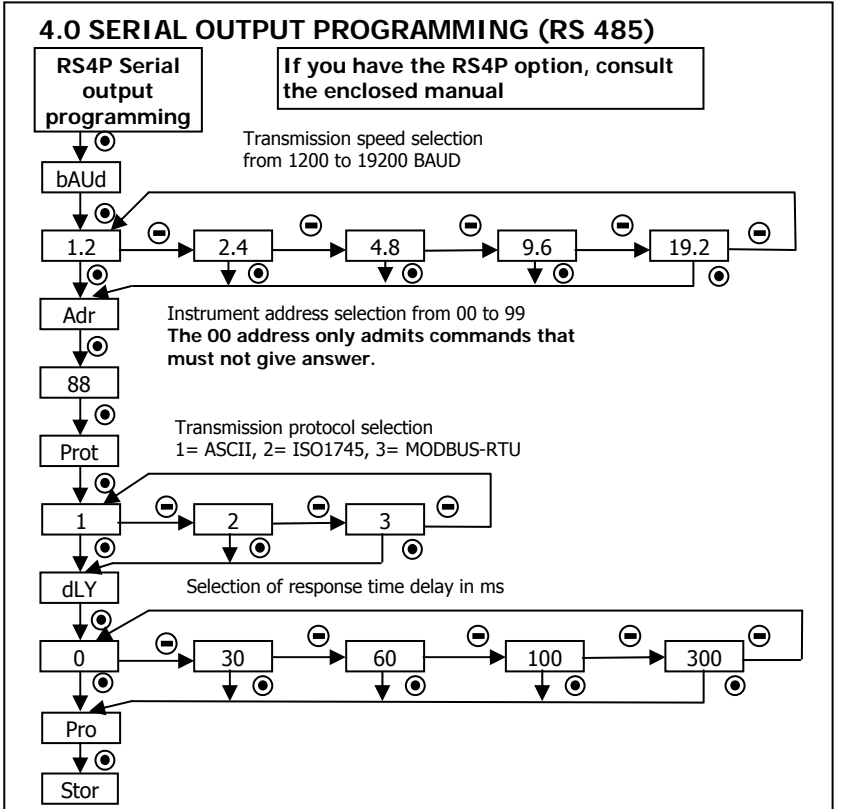
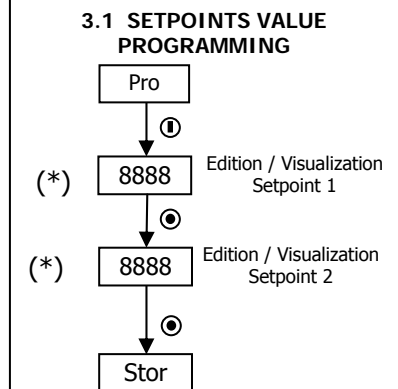

TECHNICAL SPECIFICATIONS

INPUT
 Max. Frequency 12 kHz
 Min. Frequency 0.01 Hz
 Excitation 5, 8, 12 V dc @ 60 mA (keyboard programmable)
High voltage input 10 a 600 V ac
Magnetic pick-up Vin > 30 mV eff. (60 Hz)
 Vin > 300 mV eff. (6kHz)

NAMUR Sensor
 • Rc 1.5 kΩ
 • I on < 1 mA
 • I off > 3 mA

NPN and PNP Sensors
 • Rc (NPN) 3k9 Ω, (PNP) 1k5 Ω
 • Logical levels "0" < 2.4 V, "1" > 2.6 V dc
TTL/24 V dc (encoder)
 • Logical levels "0" < 2.4 V, "1" > 2.6 V dc

Switch
 • Vc 5 V (internal)
 • Rc 3,9 kΩ (included)
 • Fc 20 Hz (automatically connected when selected switch input) (Ton, Toff > 25 ms)

ACCURACY @ 25 °C ±3.0 °C
 Max. Error ± (0.01 % of reading + 1 digit)
 Temperature coefficient 50 ppm/ °C
 Warm up 5 minutes

DISPLAY
 • Principal 9999, 4 digits 8 mm
 • Decimal point programmable
 • LEDs 2 for functions and 2 for outputs
 • Display rate 4/ s
 • Input over range ouE or D flashing
 • Display over range ouE
 • Relays, max, min refresh 10/ s

RELAYS
 • 2 Relays SPST (mounted) 5 A @ 250 Vac /30 Vdc

POWER SUPPLY
 • PICA100-F 85 VAC – 265 VAC / 100 VDC – 300 VDC
 • PICA100-F6 21 VAC – 53 VAC / 10,5 VDC – 70 VDC
 • Consumption 5W

FUSES (DIN 41661) – Not supplied
 • PICA100-F F 0.2 A / 250 V
 • PICA100-F6 F 1 A / 250 V

ENVIRONMENTAL
 • Operating Temperature -10 °C to +60 °C
 • Storage Temperature -25 °C to +85 °C
 • Relative humidity non condensed <95 % to 40 °C
 • Max. altitude 2000 meters
 • Sealed front panel IP65

DIMENSIONS
 • Dimensions 48 x 24 X 100 mm
 • Panel cutout 45 X 22 mm
 • Weight 100 g
 • Case material polycarbonate s/UL 94 V-0

DECLARATION OF CONFORMITY

Manufacturer: DITEL - Diseños y Tecnología S.A.
 Address: Polígono Industrial Les Guixeres
 C/ Xarol 8 C
 08915 BADALONA-SPAIN

Declares, that the product:
 Description: Digital panel meter multifunction
 Model: **PICA100-F**

Conforms with the directives: EMC 89/336/CEE
 LVD 73/23/CEE

| | | |
|---------------|--------------------------------|------------|
| EN 61000-6-2 | Generic immunity | Criteria B |
| EN 61000-4-2 | Electrostatic discharge | |
| | Air discharge 8kV | |
| | Contact discharge 4kV | |
| EN 61000-4-3 | Electromagnetic fields RF | Criteria A |
| | 10V/m | |
| EN 61000-4-4 | Fast transients | Criteria B |
| | Power supply Lines 2 kV | |
| | Signal Lines 1 kV | |
| EN 61000-4-5 | Surge | Criteria B |
| | AC DC | |
| | 1 kV L/N 0,5 kV | |
| | 2 kV L,N/Ground 0,5 kV | |
| EN 61000-4-6 | 1 kV Signal Lines and ground | Criteria A |
| | RF conducted interferences | |
| | 10 V rms | |
| EN 61000-4-11 | Voltage dips and interruptions | Criteria B |
| | 30% reduction 0,5 period | |
| | 66% reduction 5 per. y 50 per | Criteria C |
| EN 61000-6-3 | Generic emission | |
| | EN 55022/ CISPR22 | |
| EN 61010-1 | General safety | |
| | Installation category II | |
| | Pollution degree 2 | |
| | Conductive pollution excluded | |
| | Insulation type | |
| | Enclosure: Double | |
| | Inputs/Outputs: Basic | |

Date: 26-10-2007
 Signed: José Manuel Edo
 Function: Technical Manager

In order to guarantee the technical specifications of the instrument it is recommendable to check its calibration on a regular basis to be defined in accordance with the ISO9001 norms and the criteria of use of each application. The instrument calibration will have to be done by an accredited laboratory or directly by the manufacturer.

This manual does not represent a contractual commitment. All the information included in this manual can be modified without notice.



The instruments are warranted against defective materials and workmanship for a period of three years from date of delivery.

If a product appears to have a defect or fails during the normal use within the warranty period, please contact the distributor from which you purchased the product.

This warranty does not apply to defects resulting from action of the buyer such as mishandling or improper interfacing.

The liability under this warranty shall extend only to the repair of the instrument. No responsibility is assumed by the manufacturer for any damage which may result from its use.

All the DITEL products benefit from an unlimited and unconditional warranty of THREE (3) years from the date of their purchase. Now you can extend this period of warranty up to FIVE (5) years from the product commissioning, only by fulfilling the corresponding form.

Fill up the form in our website at:
<http://www.ditel.es/warranty>

DISEÑOS Y TECNOLOGIA, S.A.
 Polígono Industrial Les Guixeres
 C/ Xarol 8 C
 08915 BADALONA-SPAIN
 Tel: +34 - 93 339 47 58
 Fax: +34 - 93 490 31 45
 E-mail: dtl@ditel.es
www.ditel.es