

# 1/8 DIN Temperature Controller HY49



**You must read the instruction manual before starting up the equipment.**

## Wiring

The connections must be made with the instrument installed in its definite place of operation. In order to prevent electric discharges whilst making the connections, connect the instrument to the mains in the last wiring operation. The installation must be fitted with a double-pole switch of at least 1A, 250V, which must be close to the instrument and offer the operator easy access. It must be marked as the instrument's switch. Similarly, a 200 mA, 250V fuse must be fitted in the supply wiring (wiring insulation at least 1000V).

It is advisable to be guided by the following recommendations wherever possible:

- The instrument must be connected without mains voltage.
- Do not install the instrument near moving parts, contactors or motor starters.
- Endeavour to prevent mechanical vibrations.
- Do not wire the signal lines together with the power lines.
- For the signal lines, it is advisable to use a shielded wire with the earth connection at one single point.
- It is important to check the configuration of the instrument (inputs and outputs), in the event any problem occurs when starting operation.

Installation or use of the equipment other than specified in this manual may reduce the levels of protection provided in the equipment.

## Input configuration

HY49 is fully configurable; it is therefore necessary to confirm that the configuration of the instrument corresponds to the application it will be used for, prior to starting up. To change the configuration of the input signal or sensor, follow the following steps.

Each instrument is configured by default for J type input (Fe-CuNi) and it is possible to configure any thermo-couple or Pt100 (in either of their two scales), simply by changing the inP parameter. No any other modification must be made to the instrument.

To configure the input signal for voltage 0..5 VDC, 0..10 VDC, 0..20 mA or 4..20 mA, proceed as follows:

- 1) Disconnect the power supply from the instrument.
- 2) Remove the instrument through the front, releasing it using the flange located on the bottom of the front panel.
- 3) Open the instrument, separating the supply circuit from the front panel situated to the right as seen from the front.
- 4) In the circuit attached to the front of the instrument, there are four bridges which need to be changed, depending on the type of input, as is shown in the figures on the right.

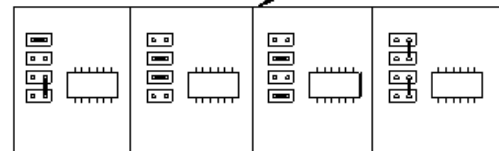
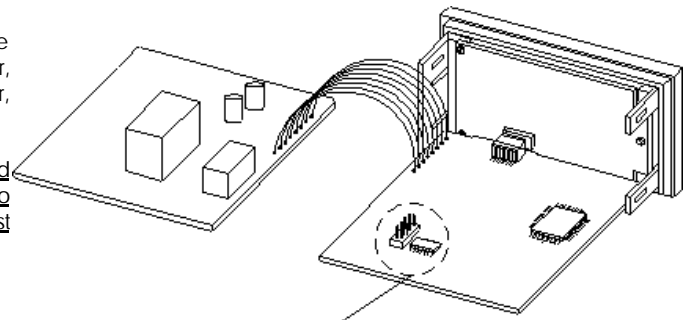

0.20 mA  
4..20 mA      0.5 V      0..10 V      Thermocouple **By default**  
Pt100

**ATTENTION:** It is very important to ensure that the value of the inP parameter corresponds to the configuration of the bridges in this circuit.

## Output Configuration

The default output configuration is as relay. If this is the desired output, none modification must be made to the instrument.

The model HY49 is equipped with the heating output configurable as a relay or voltage pulses. To change one output type to another, proceed as follows:

- 1) Disconnect the power supply from the instrument.
- 2) Remove the instrument through the front, releasing it using the flange located on the bottom of the front panel.
- 3) Open the instrument, separating the supply circuit from the front panel, located to the right as seen from the front.
- 4) Make the changes of the bridges in the circuit, as indicated in the figures below.

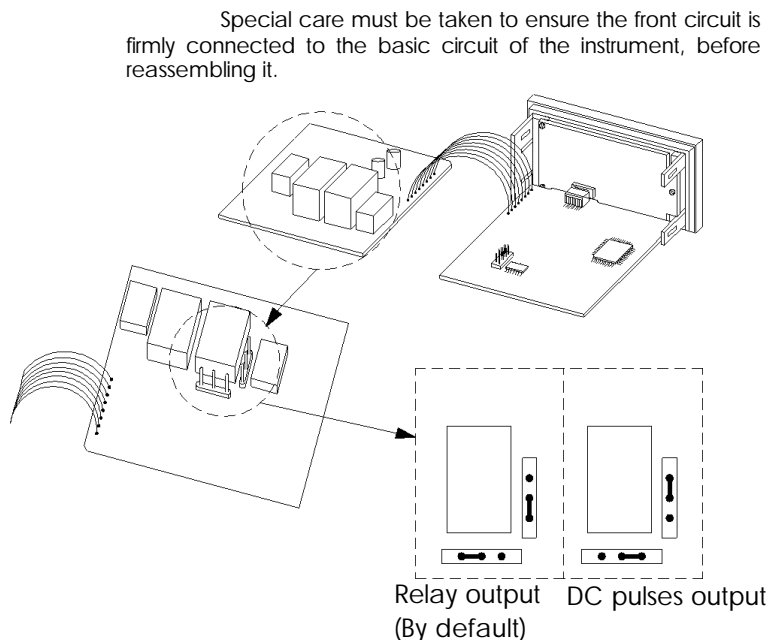

Hydra series instruments are fully configurable. This feature means there are a large number of configuration parameters. All these parameter appear following the order described below.

Parameter	Mean		Def.Value
SP	Set Point		150
Pb	Proportional Band If Pb=0 the control mode will be ON-OFF		2,5 %
Ti	Integral Time		240 s
Td	Derivative Time		60 s
Cy	Heating action cycle		20 s
Hy	Heating Hysteresis (in ON-OFF mode)		2
C.A1	Alarm 1 Configuration		0
	Value	0	Alarm Disabled
		1	Absolute Alarm, High, Direct
		2	Absolute Alarm, High, Reverse
		3	Absolute Alarm, Low, Direct
		4	Absolute Alarm, Low, Reverse
		5	Relative Alarm, High, Direct
		6	Relative Alarm, High, Reverse
		7	Relative Alarm, Low, Direct
		8	Relative Alarm, Low, Reverse
		9	Window Alarm, Direct
		10	Window Alarm, Reverse
SP.A1	Alarm 1 Absolute Set Point		155
r.A1	Alarm 1 Relative Set Point		5
C.A2	Configuración Alarm 2		0
	Value	0	Alarm Disabled
		1	Absolute Alarm, High, Direct
		2	Absolute Alarm, High, Reverse
		3	Absolute Alarm, Low, Direct
		4	Absolute Alarm, Low, Reverse
		5	Relative Alarm, High, Direct
		6	Relative Alarm, High, Reverse
		7	Relative Alarm, Low, Direct
		8	Relative Alarm, Low, Reverse
		9	Window Alarm, Direct
		10	Window Alarm, Reverse
SP.A2	Alarm 2 Absolute Set Point		155
r.A2	Alarm 2 Relative Set Point		5
BIAS	Input signal deviation		0
unit	Temperature measuring units		1
	Value	0	°F
		1	°C
out.L	Controller output limit		100
SP.LL	Set Point low limit		0
SP.HL	Set Point high limit		600
HEAT	Primary action		1
	Value	0	Cooling
		1	Heating
inP	Input type		0
	Value	0	J (0..600°C)
		1	L (0..600°C)
		2	K (0..1200°C)
		6	S (0..1600°C)
		7	Pt100 (0..600°C)
		8	Pt100 (-99,9..200,0°C)
		9	0..5 Vcc
		10	0..10 Vcc
		11	0..20 mA
		12	4..20 mA
dP	Decimal points for linear input (Only in linear inputs)		0
inL	Linear Input initial value (Only in linear inputs)		0
inH	Linear Input full scale value (Only in linear inputs)		500
Code	Keyboard unlocking code		0

## Technical

Size	1/8 DIN43700 (48 x 96 mm). Front removeable
Supply	85..265 Vac 50/60 Hz (option 21..53 Vca/cc)
Consumption	8 VA
Room temp.	0..50°C (indoor use)
Relative Humidity	Max. 80% non condensing
Altitude	Max. 2000 m
Installation Cat.	II according EN61010-1
Pollution degree	I according EN61010-1
Case	ABS self extinguishing
Dimensions	48 x 96 x 92 mm
Panel cutout	45,5 x 91,5 mm (±0,5)
Display	4 digits 10 mm for process value. 4 digits 7 mm for set point
Inputs	L: 0..600°C (Fe-CuNi, DIN43710) J : 0..600°C (Fe-CuNi, IEC584) K: 0..1200°C (NiCr-NiAl, IEC584) S: 0..1600°C (Pt/10%Rh-Pt, IEC584) RTD, Pt100: 0..600°C (IEC751) RTD, Pt100: -99,9..200,0°C (IEC751) Current loop 0..20 , 4..20 mA (10 ohm load) Vdc 0..5 , 0..10 V (>5 Kohm)
Accuracy	± 0,25% f.s.v.
Control output	Relay SPDT (2A @ 250 Vac, resistive load) or 9 Vdc pulses (open collector max. 40 mA). User configurable.
Alarms	Fully configurable. SPST output (1A @ 250 Vac, resistive load).
Weight	220 grs.

## Keyboard operation

The HY49 is equipped with 4 keys with the following functions:

▲ To be used to increase the value of certain variable during parameter configuration. In normal operating mode it can be used to display the percentage of output.

▼ To be used to decrease the value of certain variable during parameter configuration.

**FUNC** To enter in configuration mode. Each time the key is pressed, the controller shows next parameter.

↵ To be used to validate any parameter after it has been changed. In normal operating mode can be used to activate the autotuning mode only if the process value is lower than 50% of set point.

## Wiring

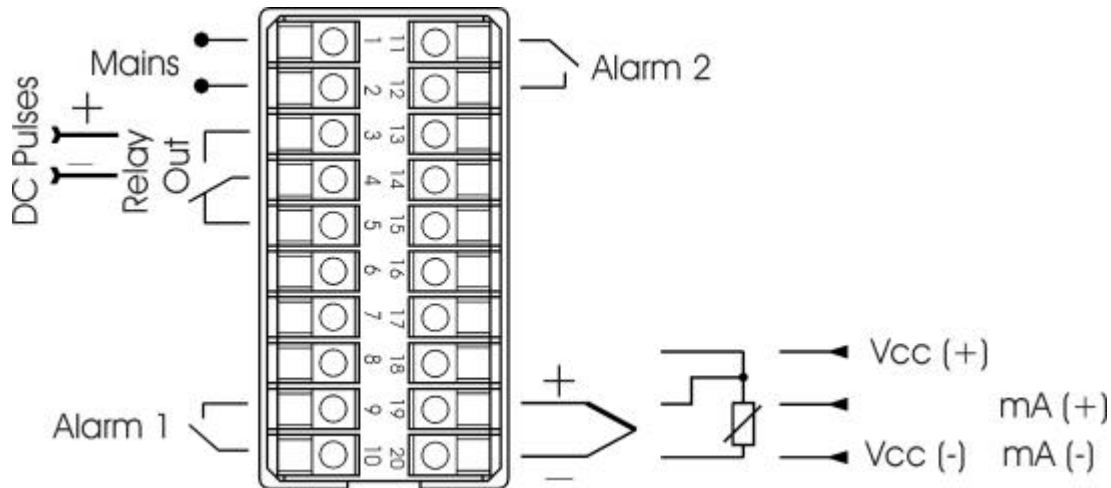

## Ordering Guide

Model	Base Options	Supply
	<b>1:</b> One SPST alarm <b>2:</b> Two SPST alarms	<b>1:</b> 85..265 Vac, 50/60 Hz <b>2:</b> 21..53 Vca/Vcc
HY49	1	1

